

Basic Information

# H1 Axial Piston Pumps

## Single and Tandem

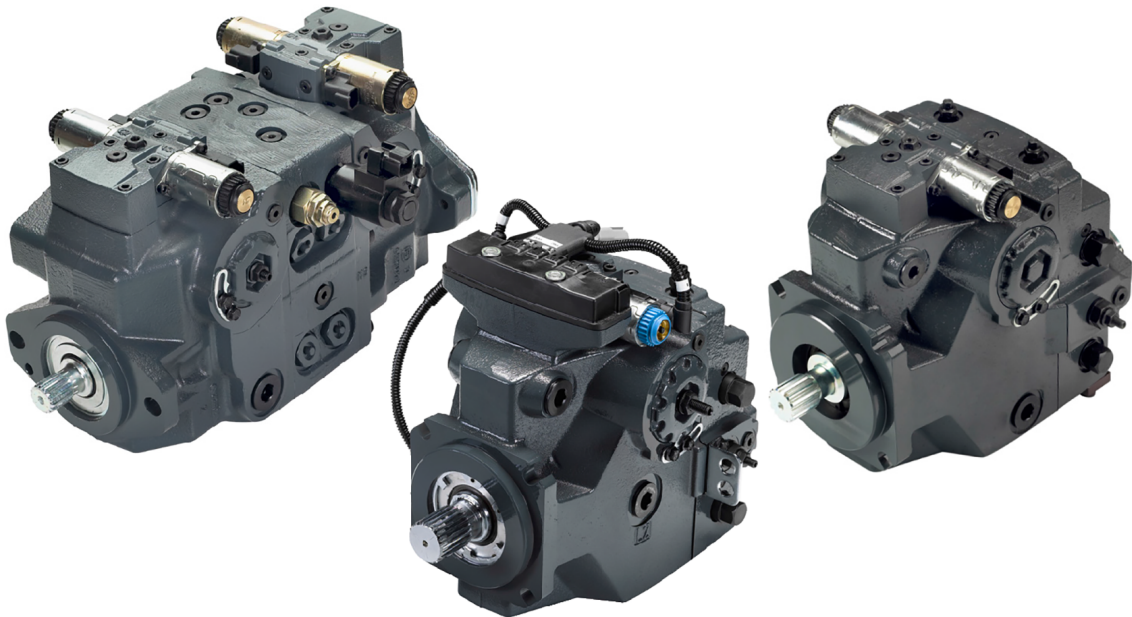

**Revision history***Table of revisions*

<b>Date</b>	<b>Changed</b>	<b>Rev</b>
May 2018	Angle sensor for EDC controls added.	0701
April 2017	NFPE and AC controls added.	0602
May 2016	Updated to Engineering Tomorrow design.	0601
Nov 2010-Nov 2015	Various changes.	BA-0501
Jul 2009	First edition.	AA

**Contents**

**Danfoss hydrostatic product family**

A word about the organization of this manual..... 4  
 General description of H1 family hydrostatic pumps.....4  
 Overview of H1 pumps technical specifications..... 5  
 H1 pumps literature reference..... 6

**Operation**

Pressure limiter valves..... 7  
 High Pressure Relief Valve (HPRV) and charge check.....7  
 Bypass function.....8  
 Charge Pressure Relief Valve (CPRV) .....9  
 Electrical Displacement Control (EDC)..... 11  
 Manual Displacement Control (MDC).....12  
 Automotive Control (AC) .....13  
 Automotive Control connection diagram ..... 15  
 Forward-Neutral-Reverse (FNR) electric control..... 16  
 Non Feedback Proportional Electric control (NFPE).....16  
 Fan Drive Control (FDC).....18  
 Manual Override (MOR).....19  
 Swash Plate Angle Sensor for EDC Controls.....20  
 Swash plate angle sensor for NFPE and AC2 controls.....21  
 Control-Cut-Off valve (CCO valve).....22  
 Displacement limiter.....23  
 Life time.....23  
 Speed and Temperature Sensor.....24  
     Description.....24  
     Theory of Operation.....24  
     Target Ring.....24  
     Mating Connectors.....24  
     Speed Sensor 4.5 – 8 V Technical Data.....25  
     Temperature Sensor Data.....25

**Operating parameters**

Input speed.....27  
 System pressure.....27  
 Servo pressure.....28  
 Charge pressure.....28  
 Charge pump inlet pressure.....28  
 Case pressure.....28  
 External shaft seal pressure.....29  
 Temperature and viscosity.....29

**System design parameters**

Filtration system.....30  
 Filtration.....31  
 Fluid selection.....36  
 Reservoir.....36  
 Case drain.....36  
 Charge pump.....37  
 Bearing loads and life .....38  
 Mounting flange loads.....39  
 Shaft torque.....41  
 Shaft availability and torque ratings.....42  
 Understanding and minimizing system noise.....43  
 Determination of nominal pump sizes.....44

**Danfoss hydrostatic product family**

**A word about the organization of this manual**

General information covering all displacements of the H1 range is given in the beginning of this manual. This includes definitions of operating parameters and system design considerations.

The next sections in the book detail the specific operating limitations for each frame and give a full breakdown of available displacements, features and options.

**General description of H1 family hydrostatic pumps**

The H1 family of closed circuit variable displacement axial piston pumps is designed for use with all existing Danfoss hydraulic motors for the control and transfer of hydraulic power. The H1 axial piston variable displacement pumps are of cradle swash-plate design and are intended for closed circuit applications.

Flow direction is reversed by tilting the swash-plate to the opposite side of the neutral (zero displacement) position. The flow rate is proportional to the pump input speed and displacement. The latter is infinitely adjustable between zero and maximum displacement.

H1 pumps can be used together in combination with other Danfoss pumps and motors in the overall hydraulic system.

- Danfoss hydrostatic products are designed with 14 different displacements (cm<sup>3</sup> [in<sup>3</sup>]):

<b>045</b>	<b>053</b>	<b>060</b>	<b>068</b>	<b>069</b>	<b>078</b>	<b>089</b>	<b>100</b>	<b>115</b>	<b>130</b>	<b>147</b>	<b>165</b>	<b>210</b>	<b>250</b>
45.0	53.8	60.4	68.0	69.0	78.0	89.2	101.7	115.8	130.8	147.0	165.0	211.5	251.7
[2.75]	[3.28]	[3.69]	[4.15]	[4.22]	[4.76]	[5.44]	[6.21]	[7.07]	[7.98]	[8.97]	[10.07]	[12.91]	[15.36]

- Danfoss hydrostatic products are designed with many different pressure, load-life and control capabilities:
  - Electric Displacement Control (EDC)
  - Forward-Neutral-Reverse control (FNR)
  - Non-Feedback Proportional Electric control (NFPE)
  - Automotive Control (AC)
  - Fan Drive Control (FDC)
  - Manual Displacement Control (MDC)
  - Control-Cut-Off valve (CCO)
- High power density where all units utilize an integral electro-hydraulic servo piston assembly that controls the rate (speed) and direction of the hydraulic flow.
- Compatible with the Danfoss family of PLUS+1® micro-controllers for easy Plug-and-Perform installation.
- More compact and lightweight
- Improved reliability and performance

Go to the Danfoss website or applicable product catalog to choose the components that are right for your complete closed circuit hydraulic system.

## H1 Axial Piston Pumps, Single and Tandem

### Danfoss hydrostatic product family

#### Overview of H1 pumps technical specifications

The table below shows the available range of H1 pumps as of this printing, with their respective speed, pressure, weight and mounting flange:

Feature	045	053	060	068	069	078	089	100	115	130	147	165	210	250
<b>Displacement cm<sup>3</sup> [in<sup>3</sup>]</b>	45.0 [2.75]	53.8 [3.28]	60.4 [3.69]	68.0 [4.15]	69.2 [4.22]	78.1 [4.77]	89.2 [5.44]	101.7 [6.21]	115.2 [7.03]	130.0 [7.93]	147.2 [8.98]	165.1 [10.08]	211.5 [12.91]	251.7 [15.36]
<b>Rated speed min<sup>-1</sup> (rpm)</b>	3400	3400	3500	3500	3500	3500	3300	3300	3200	3200	3000	3000	2600	2600
<b>Max speed min<sup>-1</sup> (rpm)</b>	3500	3500	4000	4000	4000	4000	3800	3800	3400	3400	3100	3100	2800	2800
<b>Max working pressure<sup>1)</sup> bar [psi]</b>	420 [6090]	380 [5510]	420 [6090]	380 [5510]	450 [6525]	450 [6525]	450 [6525]	450 [6525]	450 [6525]	450 [6525]	450 [6525]	450 [6525]	450 [6525]	450 [6525]
<b>Max pressure bar [psi]</b>	450 [6525]	400 [5800]	450 [6525]	400 [5800]	480 [6960]	480 [6960]	480 [6960]	480 [6960]	480 [6960]	480 [6960]	480 [6960]	480 [6960]	480 [6960]	480 [6960]
<b>Weight dry (W/O PTO, filter); kg [lb]</b>	single: 41 [90] tandem: 65 [143]		50 [110]	50 [110]	56 [123]	56 [123]	62 [137]	62 [137]	83 [187]	83 [187]	96 [211]	96 [211]	163 [360]	163 [360]
<b>Mounting flange</b>	SAE B 2-bolt	SAE B 2-bolt	SAE C 4-bolt	SAE C 4-bolt	SAE C 4-bolt	SAE C 4-bolt	SAE C 4-bolt	SAE C 4-bolt	SAE D 4-bolt	SAE D 4-bolt	SAE D 4-bolt	SAE D 4-bolt	SAE E 4-bolt	SAE E 4-bolt

<sup>1)</sup> Applied pressures above maximum working pressure requires Danfoss application approval.

#### Control options

Size	045/053 Tandem	045/053 Single	060/068	069/078	089/100	115/130	147/165	210/250
EDC	●	●	●	●	●	●	●	●
MDC	●	●	●	●	●	●	●	●
FNR	●	●	●	●	●	●	-	-
NFPE	●	●	●	●	●	●	●	●
FDC	-	●	●	●	●	●	●	●
AC	-	●	●	●	●	●	●	●

For more details go to the website <http://www.powersolutions.danfoss.com/literature/> or see *H1 pumps literature reference* on page 6.

**Danfoss hydrostatic product family**

**H1 pumps literature reference**

*Available literature for H1 Pumps*

Title	Literature Type	Order number	
		OLD	NEW
H1 Axial Piston Pumps, Single and Tandem	Product Line Overview	L1012919	AM00000001en-US
H1 Axial Piston Pumps, Single and Tandem	Basic Information	11062168	BC00000057en-US
H1 Axial Piston Tandem Pumps, Size 045/053	Technical Information	11063345	BC00000060en-US
H1 Axial Piston Single Pumps, Size 045/053	Technical Information	11063344	BC00000059en-US
H1 Axial Piston Single Pumps, Size 060/068	Technical Information	11071685	BC00000074en-US
H1 Axial Piston Single Pumps, Size 069/078	Technical Information	11062169	BC00000058en-US
H1 Axial Piston Single Pumps, Size 089/100	Technical Information	11069970	BC00000067en-US
H1 Axial Piston Single Pumps, Size 115/130	Technical Information	11063346	BC00000198en-US
H1 Axial Piston Single Pumps, Size 147/165	Technical Information	11063347	BC00000061en-US
H1 Axial Piston Single Pumps, Size 210/250	Technical Information	L1208737	BC00000207en-US
H1 Axial Piston Single Pumps, Size 045/053	Service Manual	520L0958	AX00000104en-US
H1 Axial Piston Tandem Pumps, Size 045/053	Service Manual	520L0928	AX00000103en-US
H1 Axial Piston Single Pumps, Size 069–165	Service Manual	520L0848	AX00000087en-US

[Data sheets for all pump sizes are available.](#)

*Further available literature*

Title	Literature Type	Order number	
		OLD	NEW
H1 Pump Electrical Displacement Control (EDC)	Electrical Installation	11022744	BC00000255en-US
H1 Pump 3-position Electric Control (FNR)	Electrical Installation	11025001	BC00000269en-US
H1 Pump Non-Feedback Prop. Electric (NFPE)	Electrical Installation	11025002	BC00000270en-US
H1 Pump Automotive Control (AC)	Technical Information	L1223856	BC00000213en-US
H1 Automotive on PLUS+1 for MC024	Technical Information	L1120636	BC00000201en-US
Speed and Temperature Sensor	Technical Information	11046759	BC00000047en-US
Pressure Sensor	Technical Information	L1007019	BC00000178en-US
External Remote Charge Pressure Filter	Technical Information	11064579	BC00000064en-US
Design Guideline for Hydraulic Fluid Cleanliness	Technical Information	520L0467	BC00000095en-US

Please see <http://www.powersolutions.danfoss.com/literature/>

## Operation

### Pressure limiter valves

Pressure limiter valves provide system pressure protection by compensating the pump swashplate position when the set pressure of the valve is reached. A pressure limiter is a non-dissipative (non heat generating) pressure regulating system.

Each side of the transmission loop has a dedicated pressure limiter valve that is set independently. A pump configured with pressure limiter must have pressure limiters on both sides of the system pressure loop. The pump order code allows for different pressure settings to be used at each system port.

The pressure limiter setting is the differential pressure between the high and low loops. When the pressure limiter setting is reached, the valve ports oil to the low-pressure side of the servo piston. The change in servo differential pressure rapidly reduces pump displacement. Fluid flow from the valve continues until the resulting drop in pump displacement causes system pressure to fall below the pressure limiter setting.

An active pressure limiter destrokes a pump to near neutral when the load is in a stalled condition. The pump swashplate moves in either direction necessary to regulate the system pressure, including into stroke (overrunning) or over-center (winch payout).

The pressure limiter is optional for H1 single pumps and not available for tandem pumps.

### High Pressure Relief Valve (HPRV) and charge check

All H1 pumps are equipped with a combination high pressure relief and charge check valve. The high-pressure relief function is a dissipative (with heat generation) pressure control valve for the purpose of limiting excessive system pressures. The charge check function acts to replenish the low-pressure side of the working loop with charge oil. Each side of the transmission loop has a dedicated HPRV valve that is non-adjustable with a factory set pressure. When system pressure exceeds the factory setting of the valve, oil is passed from the high pressure system loop, into the charge gallery, and into the low pressure system loop via the charge check.

The pump order code allows for different pressure settings to be used at each system port. When a HPRV valve is used in conjunction with a pressure limiter, the HPRV valve is always factory set above the setting of the pressure limiter. The system pressure order code for pumps with only HPRV is a reflection of the HPRV setting.

The system pressure order code for pumps configured with pressure limiter and HPRV is a reflection of the pressure limiter setting.

---

*HPRV's are factory set at a low flow condition. Any application or operating condition which leads to elevated HPRV flow will cause a pressure rise with flow above a valve setting. Consult factory for application review. Excessive operation of the HPRV will generate heat in the closed loop and may cause damage to the internal components of the pump.*

---

Operation

Bypass function

The single pump HPRV valve also provides a loop bypass function when each of the two HPRV hex plugs are mechanically backed out 3 full turns. Engaging the bypass function mechanically connects both A & B sides of the working loop to the common charge gallery. The bypass function allows a machine or load to be moved without rotating the pump shaft or prime move.

Bypass function not available for tandem pumps.

**Caution**

Excessive speeds and extended load/vehicle movement must be avoided. The load or vehicle should be moved not more than 20 % of maximum speed and for a duration not exceeding 3 minutes. Damage to drive motor(s) is possible. When the bypass function is no longer needed care should be taken to reset the HPRV hex plugs to the normal operating position.

System schematic, single pump

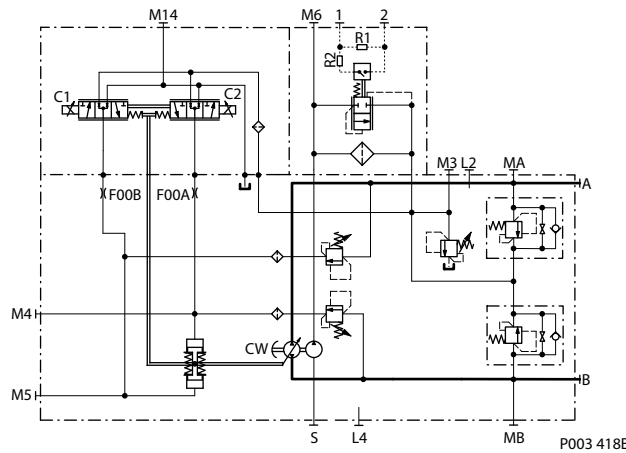

System schematic, tandem pump

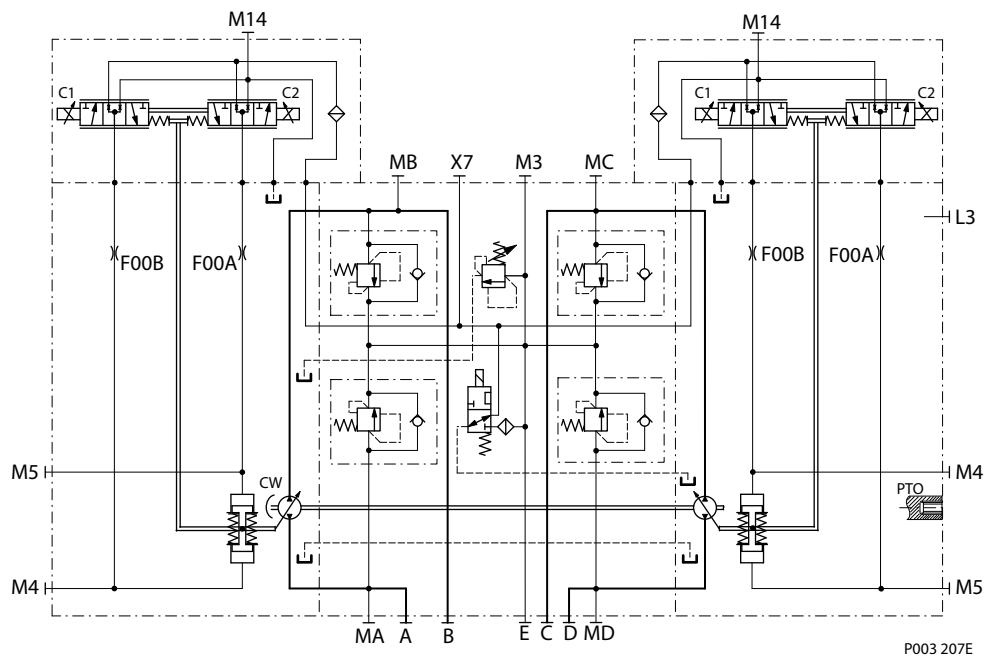



**Operation**

**Charge Pressure Relief Valve (CPRV)**

The charge pressure relief valve is a direct acting poppet valve which opens and discharges fluid to the pump case when pressure exceeds a designated level. The charge pressure relief valve maintains charge pressure at a designated level above case pressure. This level is nominally set with the pump running at 1800 rpm.

In forward or reverse, charge pressure will be slightly lower than when in neutral position. The charge pressure relief valve setting is specified on the model code of the pump. Typical charge pressure increase from 1.2 - 1.5 bar per 10 l/min [17.4 - 21.8 psi per 2.64 US gal/min]. For external charge flow the CPRV is set according to the table below:

*Charge pressure relief valve flow setting for external charge supply*

<b>Single 045/053</b>	15 l/min	3.9 US gal/min
<b>Tandem 045/053</b>	30 l/min	7.9 US gal/min
<b>Single 060/068/069/078/089/100/115/130/147/165</b>	22.7 l/min	6.0 US gal/min
<b>Single 210/250</b>	40.0 l/min	106 US gal/min

*System schematic, single pump*

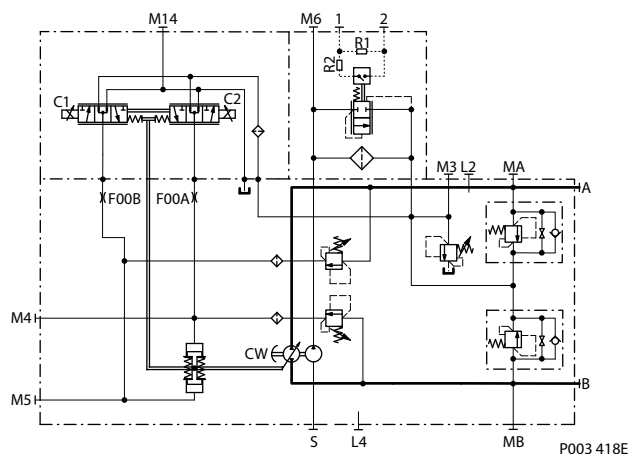

**Operation**

*System schematic, tandem pump*

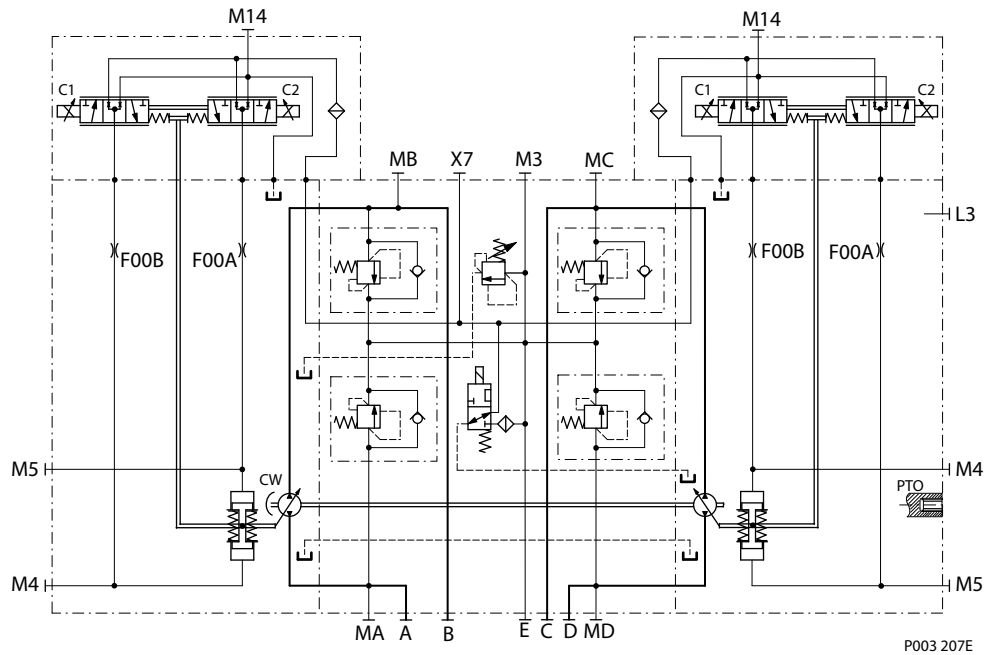

**Operation**

**Electrical Displacement Control (EDC)**

**EDC principle**

An EDC is a displacement (flow) control. Pump swashplate position is proportional to the input command and therefore vehicle or load speed (excluding influence of efficiency), is dependent only on the prime mover speed or motor displacement.

The Electrical Displacement Control (EDC) consists of a pair of proportional solenoids on each side of a three-position, four-way porting spool. The proportional solenoid applies a force input to the spool, which ports hydraulic pressure to either side of a double acting servo piston. Differential pressure across the servo piston rotates the swashplate, changing the pump's displacement from full displacement in one direction to full displacement in the opposite direction. Under some circumstances, such as contamination, the control spool could stick and cause the pump to stay at some displacement.

A serviceable 125 µm screen is located in the supply line immediately before the control porting spool.

*EDC control*

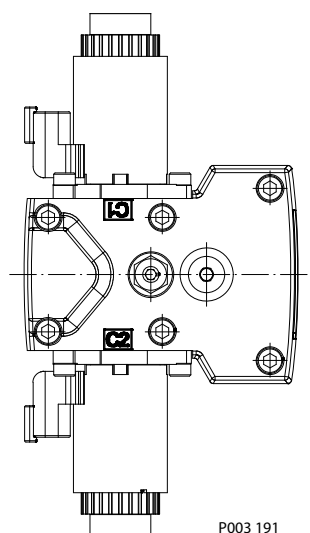

*EDC schematic*

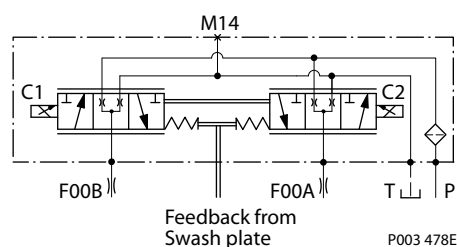

**EDC operation**

EDC's are current driven controls requiring a Pulse Width Modulated (PWM) signal. Pulse width modulation allows more precise control of current to the solenoids. The PWM signal causes the solenoid pin to push against the porting spool, which pressurizes one end of the servo piston, while draining the other. Pressure differential across the servo piston moves the swashplate.

A swashplate feedback link, opposing control links, and a linear spring provide swashplate position force feedback to the solenoid. The control system reaches equilibrium when the position of the swashplate spring feedback force exactly balances the input command solenoid force from the operator. As hydraulic pressures in the operating loop change with load, the control assembly and servo/swashplate system work constantly to maintain the commanded position of the swashplate.

**Operation**

The EDC incorporates a positive neutral deadband as a result of the control spool porting, preloads from the servo piston assembly, and the linear control spring. Once the neutral threshold current is reached, the swashplate is positioned directly proportional to the control current. To minimize the effect of the control neutral deadband, we recommend the transmission controller or operator input device incorporate a jump up current to offset a portion of the neutral deadband.

The neutral position of the control spool does provide a positive preload pressure to each end of the servo piston assembly.

When the control input signal is either lost or removed, or if there is a loss of charge pressure, the spring-loaded servo piston will automatically return the pump to the neutral position.

**Manual Displacement Control (MDC)**

**MDC principle**

The Manual Displacement Control, or MDC, consists of a handle on top of a rotary input shaft. The shaft provides an eccentric connection to a feedback link. This link is connected on its one end with a porting spool. On its other end the link is connected the pumps swashplate. This design provides a travel feedback without spring. When turning the shaft the spool moves thus providing hydraulic pressure to either side of a double acting servo piston of the pump.

Differential pressure across the servo piston rotates the swash plate, changing the pump's displacement. Simultaneously the swashplate movement is fed back to the control spool providing proportionality between shaft rotation on the control and swashplate rotation. The MDC changes the pump displacement between no flow and full flow into opposite directions.

The MDC is sealed by means of a static O-ring between the actuation system and the control block. Its shaft is sealed by means of a special O-ring which is applied for low friction. The special O-ring is protected from dust, water and aggressive liquids or gases by means of a special lip seal.

*MDC control*

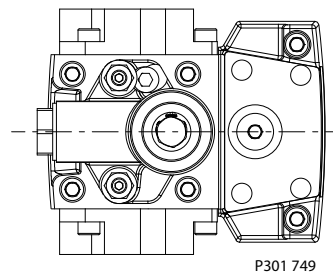

*MDC schematic diagram*

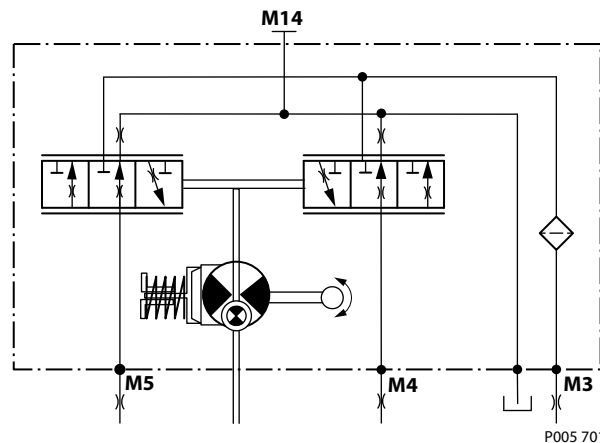

## Operation

### MDC operation

In difference to other controls the MDC spool provides a mechanical deadband. This is required to overcome the tolerances in the mechanical actuation.

The MDC contains an internal end stop to prevent turning the handle into any inappropriate position. The internal end stop is not applicable for any limitation of the Bowden cable stroke, except the applied torque to the shaft will never exceed 20 Nm. Customers must install some support to limit the setting range of their Bowden cable.

The MDC provides a permanent restoring moment in direction to its neutral position. This is required to take the backlash out of the mechanical connections between the Bowden cable and the control. The restoring moment is appropriate turning the shaft back to neutral when the connection to the Bowden cable is lost. It is not appropriate to force a Bowden cable or a joystick back to neutral!

### Neutral Start Switch

MDC controls are available with neutral start switch (NSS). The NSS contains an electrical switch that provides a signal of whether the control is in neutral. The signal in neutral is normally closed (NC).

*MDC NSS schematic diagram*

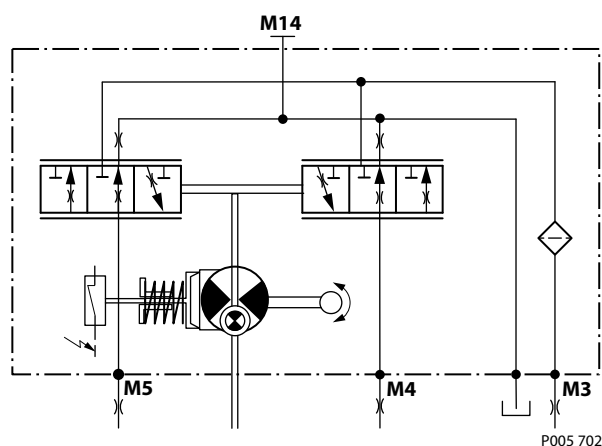

## Automotive Control (AC)

The AC-1 and AC-2 propel transmission system consists of an H1 variable pump, embedded electronic controller, and service tool configurable PLUS+1® software that allows the customer to completely optimize vehicle performance. The embedded electronic controller provides an electric input signal activating one of two solenoids that port charge pressure to either side of the pump servo cylinder. The AC has no mechanical feedback mechanism but AC-2 is available with an electronic feedback signal for the swash plate position.

The pump displacement is proportional to the solenoid signal current, but it also depends upon pump input speed and system pressure. This characteristic also provides a power limiting function by reducing the pump swash plate angle as system pressure increases. A typical response characteristic is shown in the accompanying graph.

Under some circumstances, such as contamination, the control spool could stick and cause the pump to stay at some displacement.

A serviceable 125 µm screen is located in the supply line immediately before the control porting spool.

**Operation**

*Automotive Control (AC)*

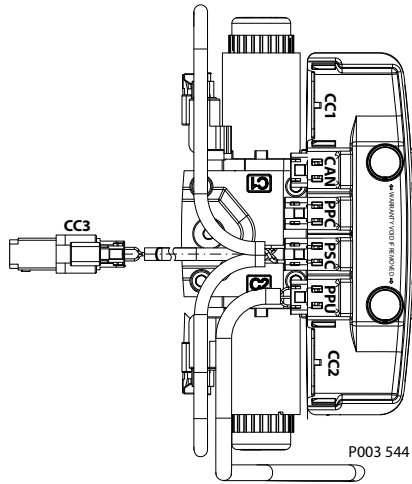

*Automotive Control (AC) schematic*

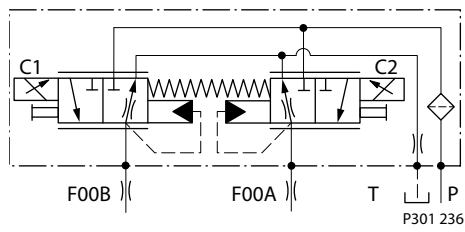

Operation

Automotive Control connection diagram

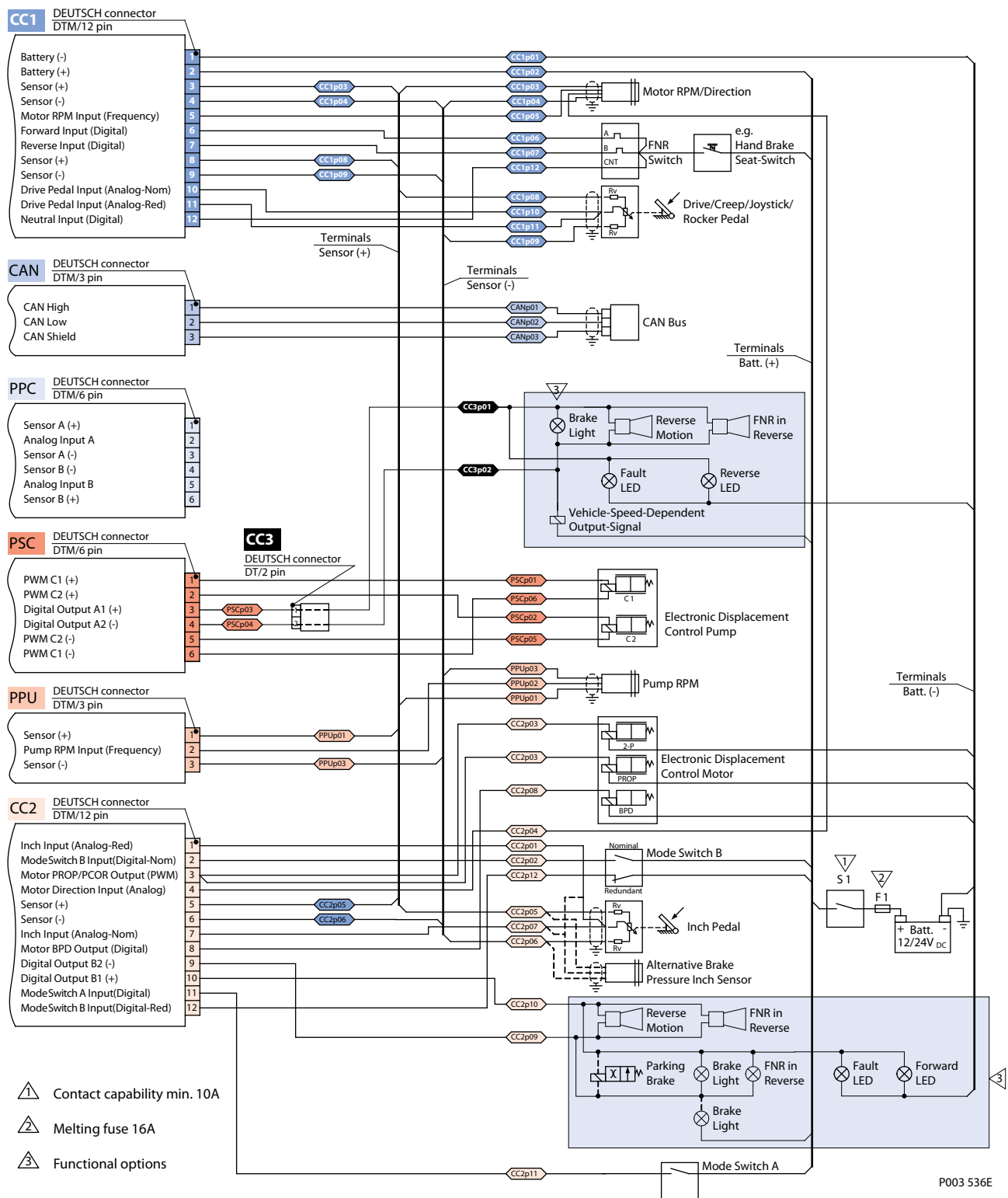

**Operation**

**Forward-Neutral-Reverse (FNR) electric control**

The 3-Position (F-N-R) control uses an electric input signal to switch the pump to a full stroke position. Under some circumstances, such as contamination, the control spool could stick and cause the pump to stay at some displacement. A serviceable 125 µm screen is located in the supply line immediately before the control porting spool.

*FNR control*

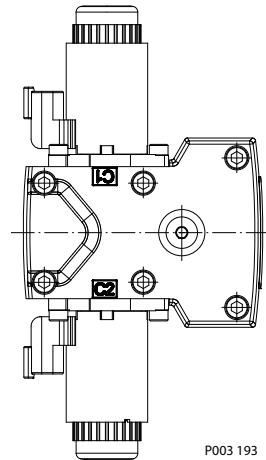

*3-Position electric control, hydraulic schematic*

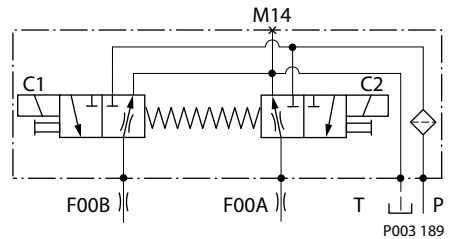

**Non Feedback Proportional Electric control (NFPE)**

The Non Feedback Proportional Electric (NFPE) control is an electrical automotive control in which an electrical input signal activates one of two proportional solenoids that port charge pressure to either side of the pump servo cylinder. The NFPE control has no mechanical feedback mechanism. The pump displacement is proportional to the solenoid signal current, but it also depends upon pump input speed and system pressure. This characteristic also provides a power limiting function by reducing the pump swashplate angle as system pressure increases. Under some circumstances, such as contamination, the control spool could stick and cause the pump to stay at some displacement. A serviceable 125 µm screen is located in the supply line immediately before the control porting spool.

*NFPE control*

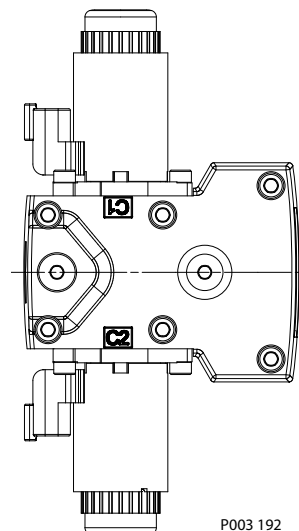



**Operation**

*NFPE schematic*

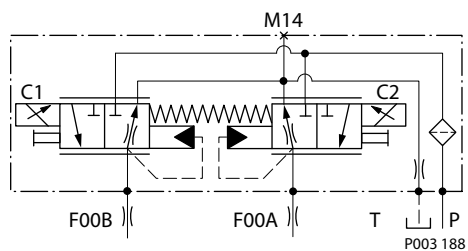

**Operation**

**Fan Drive Control (FDC)**

The Fan Drive Control (FDC) is a non-feedback control in which an electrical input signal activates the proportional solenoid that ports charge pressure to either side of the pump servo cylinder.

The single proportional solenoid is used to control pump displacement in the forward or reverse direction.

The control spool is spring biased to produce maximum forward pump displacement in the absence of an electrical input signal. Based on the spring bias spool default forward flow for a CW rotation pump is out of Port B while default forward flow for a CCW rotation pump is out of Port A.

*FDC control*

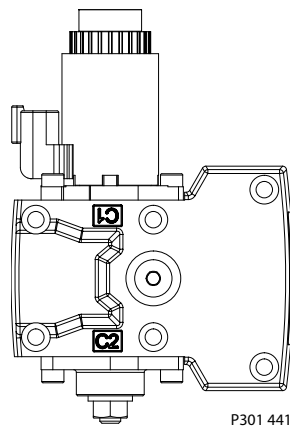

*FDC schematic*

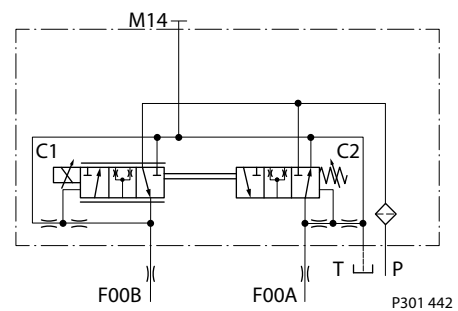

*Pump displacement vs. control current*

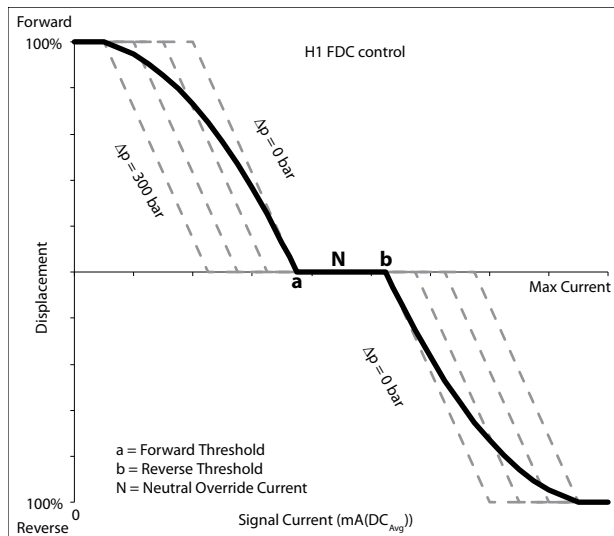

The pump displacement is proportional to the solenoid signal current, but it also depends upon pump input speed and system pressure. This characteristic also provides a power limiting function by reducing the pump swash plate angle as system pressure increases. The pump should be configured with 0.8 mm control orifices to provide slowest response and maximize system stability. Additionally pressure limiter (PL) valves are used to limit maximum fan trim speed in both forward and reverse directions.

Under some circumstances, such as contamination, the control spool could stick and cause the pump to stay at some displacement.

**Operation**

**Manual Override (MOR)**

All controls are available with a manual override functionality (MOR), either standard or as an option for temporary actuation of the control to aid in diagnostics.

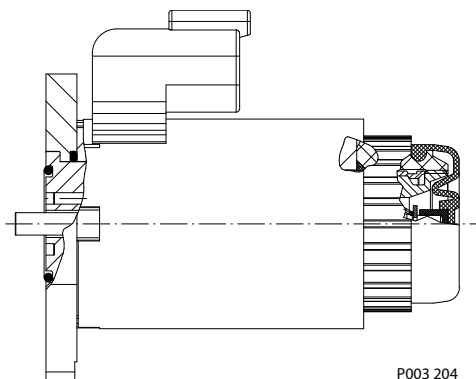

MOR schematic (EDC shown)

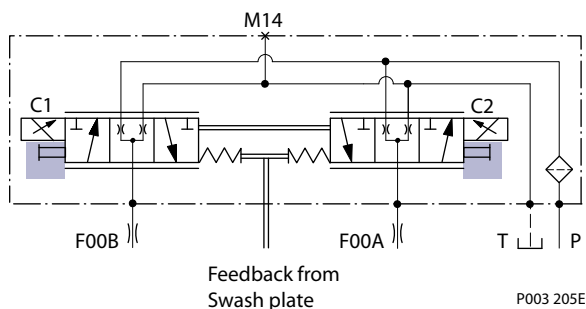

Unintended MOR operation will cause the pump to go into stroke. The vehicle or device must always be in a safe condition (i.e. vehicle lifted off the ground) when using the MOR function.

The MOR plunger has a 4 mm diameter and must be manually depressed to be engaged. Depressing the plunger mechanically moves the control spool which allows the pump to go on stroke. The MOR should be engaged anticipating a full stroke response from the pump.

An o-ring seal is used to seal the MOR plunger where initial actuation of the function will require a force of 45 N to engage the plunger. Additional actuations typically require less force to engage the MOR plunger.

Proportional control of the pump using the MOR should not be expected.

Refer to the control flow table in the size specific technical information for the relationship of solenoid to direction of flow.

## Operation

### Swash Plate Angle Sensor for EDC Controls

The angle sensor detects the swash plate position with an accuracy dependent upon the calibration effort done for the application and direction of rotation from the neutral position. At minimum the sensor can be used for forward, neutral and reverse (FNR) detection.

The sensor works on the hall-effect technology. The implemented technology is based on a measurement of the magnetic field direction in parallel to the chip surface. This field direction is converted to a voltage signal at the output.

Enhanced calibration of the non-linear behavior leads to more exact calculation of the pump swash plate angle.

The 4-pin DEUTSCH connector is part of the sensor housing.

The swash plate angle sensor is available for all EDC controls for 12 V and 24 V.

*Swash plate angle vs. output of supply voltage*

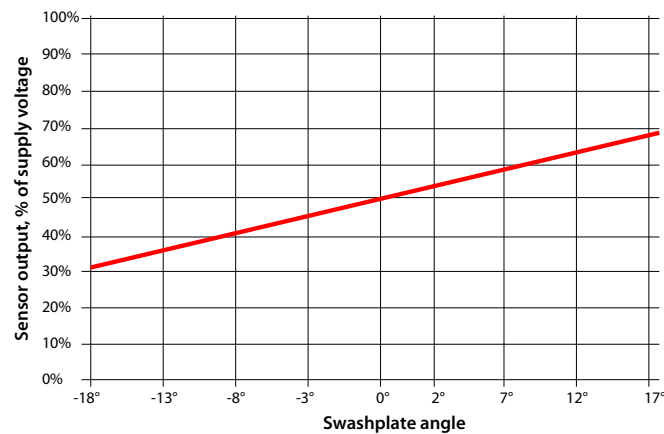

---

**Strong magnetic fields in the proximity of the sensor can influence the sensor signal and must be avoided.**

---

[Contact your Danfoss representative in case the angle sensor will be used for safety functions.](#)

---

**Operation**

**Swash plate angle sensor for NFPE and AC2 controls**

The angle sensor detects the swash plate angle position and direction of rotation from the zero position. The swash angle sensor works on the AMR sensing technology. Under the saturated magnetic field, the resistance of the element varies with the magnetic field direction.

The output signal give a linear output voltage for the various magnet positions in the sensing range.

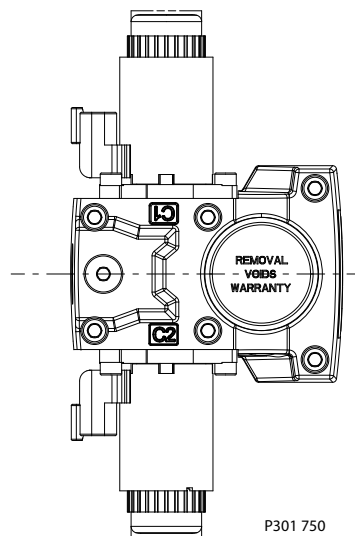

Swash plate angle vs. output voltage

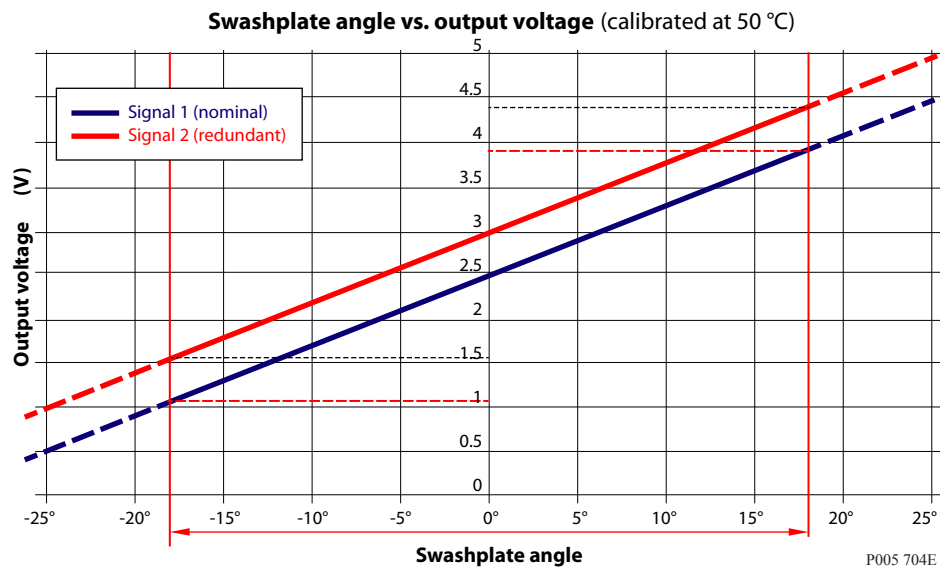

**Operation**

**Control-Cut-Off valve (CCO valve)**

The pump offers an optional control cut off valve integrated into the control. This valve will block charge pressure to the control, allowing the servo springs to de-stroke both pumps regardless of the pump's primary control input. There is also a hydraulic logic port, X7, which can be used to control other machine functions, such as spring applied pressure release brakes. The pressure at X7 is controlled by the control cut off solenoid. The X7 port would remain plugged if not needed.

In the normal (de-energized) state of the solenoid charge flow is prevented from reaching the controls. At the same time the control passages and the X7 logic port are connected and drained to the pump case. The pump will remain in neutral, or return to neutral, independent of the control input signal. Return to neutral time will be dependent on oil viscosity, pump speed, swashplate angle, and system pressure.

When the solenoid is energized, charge flow and pressure is allowed to reach the pump control. The X7 logic port will also be connected to charge pressure and flow.

The solenoid control is intended to be independent of the primary pump control making the control cut off an override control feature. It is however recommended that the control logic of the CCO valve be maintained such that the primary pump control signal is also disabled whenever the CCO valve is de-energized. Other control logic conditions may also be considered.

MDC and EDC controls are available with a CCO valve.

The response time of the unit depends on the control type and the used control orifices.

The CCO-valve is available with 12 V or 24 V solenoid.

*CCO-schematic (MDC shown)*

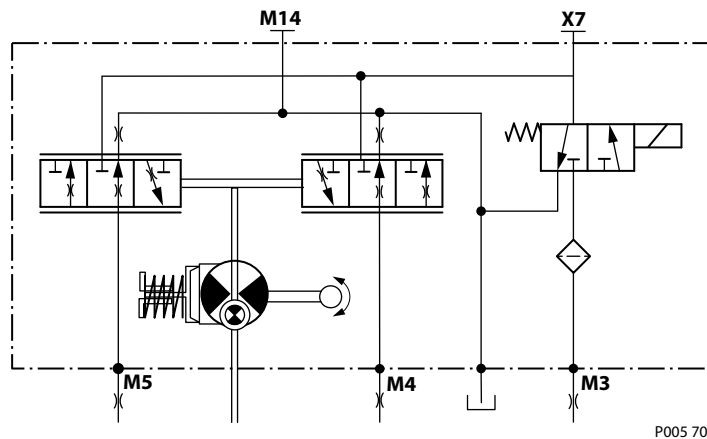

P005 703

**Operation**

**Displacement limiter**

All H1 pumps are designed with optional mechanical displacement (stroke) limiters factory set to max. displacement.

The maximum displacement of the pump can be set independently for forward and reverse using the two adjustment screws to mechanically limit the travel of the servo piston down to 50 % displacement. Adjustment procedures are found in the H1 Service Manual. Adjustments under operating conditions may cause leakage. The adjustment screw can be completely removed from the threaded bore if backed out to far.

*Displacement limiter*

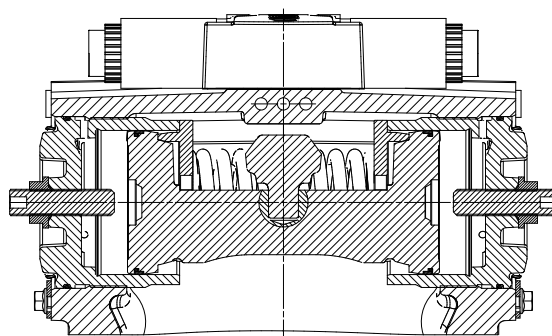

P003 266

**Life time**

The life of the product depends on several factors, such as speed, pressure, swash plate angle, to name a few. For detailed product life calculation, please contact your Danfoss representative.

## Operation

### Speed and Temperature Sensor

#### Description

Function of the speed sensor is to detect the shaft speed. Typically the sensor is mounted to the housing of a Danfoss pump or motor and senses the speed from a target ring that is rotating inside the pump or motor.

Because of the digital output signals for speed the sensor is ideal for high and low speed measurements.

The speed sensor is designed for rugged outdoor, mobile or heavy industrial speed sensing applications.

The detection of the speed is contactless. It is custom-designed for Danfoss. It is a *Plug and Perform* device that does not need any calibration or adjustments.

For diagnostics and other purposes, some sensor also has the capability to detect the driving direction and the case oil temperature.

#### Theory of Operation

The speed sensor is externally powered and, in response to the speed of the target ring, outputs a digital pulse signal. A magnet inside the sensor provides the magnetic field that changes with the position of the target teeth.

The target ring is attached to the cylinder block or the shaft. Hall sensors change from high/low state as the target teeth pass by the sensor's face. The digital (on-off-on-off) pulse train is fed to a controller, which interprets its rate of change as a speed.

Some speed sensor uses two Hall sensors with specific distance and orientation resulting in a pulse train output shift of 90° between the two sensors. A logic circuit decodes the two signals to provide an additional direction indication (high or low depending on direction).

Due to the design of the sensor, the duty cycle (ratio between on and off time at constant speed) of both speed signals at any working condition is close to 50 % and can be used for better resolution at low speeds.

#### Target Ring

Speed (target) rings vary according to the diameter of the cylinder block or shaft on which they are installed. The number of teeth is shown in the table below.

*The number of speed (target) ring teeth*

H1P size	045/053	060/068	069/078	089/100	115/130	147/165	210/250
Teeth	79	86	86	92	102	108	90

#### Mating Connectors

Mating connectors ordering data.

*Ordering data*

Description	Quantity	Ordering number
Mating connector	1	DEUTSCH DT06-6S
Wedge lock	1	DEUTSCH WM65
Socket contact (16 and 18 AWG)	6	DEUTSCH 0462-201-2031
DEUTSCH mating connector kit	1	11033865



## Operation

### Speed Sensor 4.5 – 8 V Technical Data

Speed sensor 6-pin connector

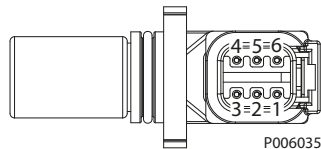

Pinout:

1. Speed signal 2
2. Direction signal
3. Speed signal 1
4. Supply
5. Ground
6. Temperature

Technical data

Parameter	Min.	Nom.	Max.	Note
Supply voltage	4.5 V <sub>DC</sub>	5 V <sub>DC</sub>	8 V <sub>DC</sub>	Regulated supply voltage. Reverse polarity protected.
Supply protection	–	–	30 V <sub>DC</sub>	Shuts off above 9 V.
Max. required supply current	–	–	25 mA	At supply voltage
Max. output current	–	–	50 mA	
Operation mode	NPN & PNP			Push-Pull amplifier
Temperature signal	-40°C = 2.318V	–	100°C = 0.675V	
Output low speed signal	5 %	8.5 %	12 %	Ratiometric output voltage Low state > 0 V to provide wire fault detection
Output high speed signal	88 %	91.5 %	95 %	
Detectable frequency range	1 Hz	–	10 000 Hz	
Ordering number	149055			
Color of connector	Black			

### Temperature Sensor Data

For calculation of the case fluid temperature and the output signal voltage, see the formulas below:

#### $V_O$ – Measured output voltage (V)

$$V_O = (-3.88 \cdot 10^{-6} \cdot T^2) + (-1.15 \cdot 10^{-2} \cdot T) + 1.8639$$

#### $T$ – Temperature (°C)

$$T = -1481.96 + \sqrt{2.1962 \cdot 10^6 + \frac{(1.8639 - V_O)}{3.88 \cdot 10^6}}$$

Output signal voltage vs. Temperature

Temperature range							
-55 °C**	-40 °C	-30 °C	0 °C	+30 °C*	+80 °C	+100 °C	+130 °C**
2.485 V	2.318 V	2.205 V	1.864 V	1.515 V	0.919 V	0.675 V	0.303 V

\* Accuracy: ±1.5 to ±4 °C

\*\* Accuracy: ±2.5 to ±5 °C

**Operation**

**Response time in fluid**

*T<sub>90</sub> definition*

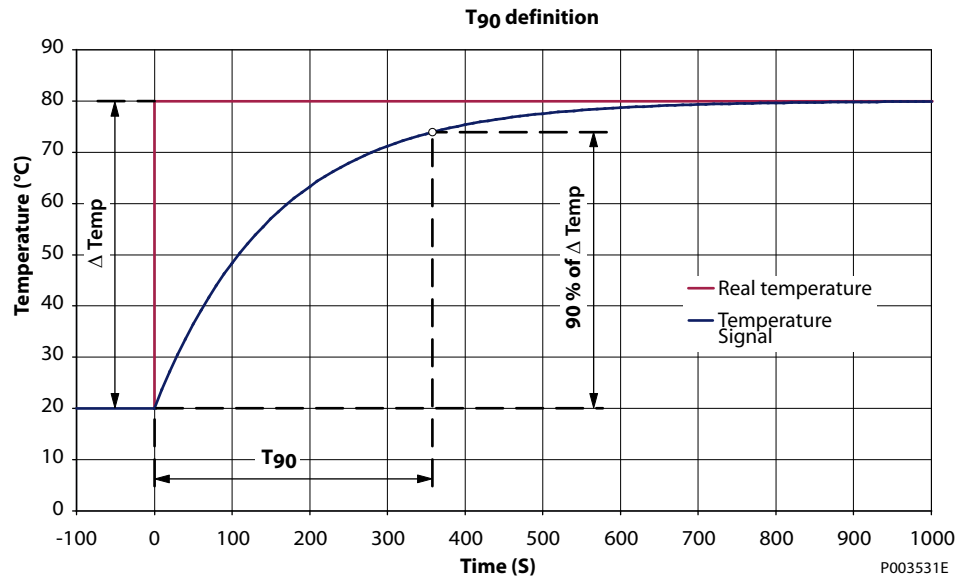

Response time in fluid ( $T_{90}$ ) = 360 s

## Operating parameters

### Input speed

**Minimum speed** is the lowest input speed recommended during engine idle condition. Operating below minimum speed limits the pump's ability to maintain adequate flow for lubrication and power transmission.

**Rated speed** is the highest input speed recommended at full power condition. Operating at or below this speed should yield satisfactory product life.

**Maximum speed** is the highest operating speed permitted. Exceeding maximum speed reduces product life and can cause loss of hydrostatic power and braking capacity. Never exceed the maximum speed limit under any operating conditions.

Operating conditions between Rated and Maximum speed should be restricted to less than full power and to limited periods of time. For most drive systems, maximum unit speed occurs during downhill braking or negative power conditions.

For more information consult *Pressure and speed limits, BLN-9884*, when determining speed limits for a particular application.

---

During hydraulic braking and downhill conditions, the prime mover must be capable of providing sufficient braking torque in order to avoid pump over speed. This is especially important to consider for turbocharged and Tier 4 engines.

---

### **Warning**

#### **Unintended vehicle or machine movement hazard**

Exceeding maximum speed may cause a loss of hydrostatic drive line power and braking capacity. You must provide a braking system, redundant to the hydrostatic transmission, sufficient to stop and hold the vehicle or machine in the event of hydrostatic drive power loss. The braking system must also be sufficient to hold the machine in place when full power is applied.

---

### System pressure

**System pressure** is the differential pressure between high pressure system ports. It is the dominant operating variable affecting hydraulic unit life. High system pressure, which results from high load, reduces expected life. Hydraulic unit life depends on the speed and normal operating, or weighted average, pressure that can only be determined from a duty cycle analysis.

**Application pressure** is the high pressure relief or pressure limiter setting normally defined within the order code of the pump. This is the applied system pressure at which the driveline generates the maximum calculated pull or torque in the application.

**Maximum working pressure** is the highest recommended application pressure. Maximum working pressure is not intended to be a continuous pressure. Propel systems with application pressures at, or below, this pressure should yield satisfactory unit life given proper component sizing.

**Maximum pressure** is the highest allowable application pressure under any circumstance. Application pressures above Maximum Working Pressure will only be considered with duty cycle analysis and factory approval.

---

Pressure spikes are normal and must be considered when reviewing Maximum Working pressure.

---

**Minimum low loop pressure** must be maintained under all operating conditions to avoid cavitation.

---

All pressure limits are differential pressures referenced to low loop (charge) pressure. Subtract low loop pressure from gauge readings to compute the differential.

---

## Operating parameters

### Servo pressure

Servo pressure is the pressure in the Servosystem needed to position and hold the pump on stroke. It depends on system pressure and speed. At minimum servo pressure the pump will run at reduced stroke depending on speed and pressure.

**Minimum servo pressure** at corner power holds the pump on full stroke at max speed and max pressure.

**Maximum servo pressure** is the highest pressure typically given by the charge pressure setting.

### Charge pressure

An internal charge relief valve regulates charge pressure. Charge pressure supplies the control with pressure to operate the swashplate and to maintain a minimum pressure in the low side of the transmission loop.

The charge pressure setting listed in the order code is the set pressure of the charge relief valve with the pump in neutral, operating at 1800 min<sup>-1</sup> [rpm], and with a fluid viscosity of 32 mm<sup>2</sup>/s [150 SUS].

Pumps configured with no charge pump (external charge supply) are set with a charge flow of 30 l/min [7.93 US gal/min] and a fluid viscosity of 32 mm<sup>2</sup>/s [150 SUS].

The charge pressure setting is referenced to case pressure. Charge pressure is the differential pressure above case pressure.

**Minimum charge pressure** is the lowest pressure allowed to maintain a safe working condition in the low side of the loop. Minimum control pressure requirements are a function of speed, pressure, and swashplate angle, and may be higher than the minimum charge pressure shown in the Operating parameters tables.

**Maximum charge pressure** is the highest charge pressure allowed by the charge relief adjustment, and which provides normal component life. Elevated charge pressure can be used as a secondary means to reduce the swashplate response time.

### Charge pump inlet pressure

At normal operating temperature charge inlet pressure must not fall below *rated charge inlet pressure (vacuum)*. **Minimum charge pump inlet pressure** is only allowed at cold start conditions. In some applications it is recommended to warm up the fluid (e.g. in the tank) before starting the engine and then run the engine at limited speed. Maximum charge pump inlet pressure may be applied continuously.

### Case pressure

Under normal operating conditions, the rated case pressure must not be exceeded. During cold start case pressure must be kept below maximum intermittent case pressure. Size drain plumbing accordingly.

Auxiliary Pad Mounted Pumps. The auxiliary pad cavity of H1 pumps configured without integral charge pumps is referenced to case pressure. Units with integral charge pumps have auxiliary mounting pad cavities referenced to charge inlet (vacuum).

#### **Caution**

---

#### **Possible component damage or leakage.**

Operation with case pressure in excess of stated limits may damage seals, gaskets, and/or housings, causing external leakage. Performance may also be affected since charge and system pressure are additive to case pressure.

---

**Operating parameters****External shaft seal pressure**

In certain applications, the input shaft seal may be exposed to external pressures. The shaft seal is designed to withstand an external pressure up to 0.4 bar [5.8 psi] above the case pressure. The case pressure limits must also be followed to ensure the shaft seal is not damaged.

**Temperature and viscosity****Temperature**

The high temperature limits apply at the hottest point in the transmission, which is normally the motor case drain. The system should generally be run at or below the quoted *rated temperature*.

The **maximum intermittent temperature** is based on material properties and should never be exceeded.

Cold oil will generally not affect the durability of the transmission components, but it may affect the ability of oil to flow and transmit power; therefore temperatures should remain 16 °C [30 °F] above the pour point of the hydraulic fluid.

The **minimum temperature** relates to the physical properties of component materials.

Size heat exchangers to keep the fluid within these limits. Danfoss recommends testing to verify that these temperature limits are not exceeded.

**Viscosity**

For maximum efficiency and bearing life, ensure the fluid viscosity remains in the *recommended range*.

The **minimum viscosity** should be encountered only during brief occasions of maximum ambient temperature and severe duty cycle operation.

The **maximum viscosity** should be encountered only at cold start.

**System design parameters**

**Filtration system**

To prevent premature wear, ensure only clean fluid enters the hydrostatic transmission circuit. A filter capable of controlling the fluid cleanliness to ISO 4406 class 22/18/13 (SAE J1165) or better, under normal operating conditions, is recommended. These cleanliness levels can not be applied for hydraulic fluid residing in the component housing/case or any other cavity after transport.

The filter may be located on the pump (integral) or in another location (remote). The integral filter has a filter bypass sensor to signal the machine operator when the filter requires changing. Filtration strategies include suction or pressure filtration.

The selection of a filter depends on a number of factors including the contaminant ingress rate, the generation of contaminants in the system, the required fluid cleanliness, and the desired maintenance interval. Filters are selected to meet the above requirements using rating parameters of efficiency and capacity.

Filter efficiency can be measured with a Beta ratio ( $\beta_x$ ). For simple suction filtered closed circuit transmissions and open circuit transmissions with return line filtration, a filter with a  $\beta$ -ratio within the range of  $\beta_{35-45} = 75$  ( $\beta_{10} \geq 2$ ) or better has been found to be satisfactory.

For some open circuit systems, and closed circuits with cylinders being supplied from the same reservoir, a considerably higher filter efficiency is recommended. This also applies to systems with gears or clutches using a common reservoir.

For these systems, a charge pressure or return filtration system with a filter  $\beta$ -ratio in the range of  $\beta_{15-20} = 75$  ( $\beta_{10} \geq 10$ ) or better is typically required.

Because each system is unique, only a thorough testing and evaluation program can fully validate the filtration system.

Please see *Design Guidelines for Hydraulic Fluid Cleanliness Technical Information*, **520L0467** for more information.

---

Filter  $\beta_x$ -ratio is a measure of filter efficiency defined by ISO 4572. It is defined as the ratio of the number of particles greater than a given diameter (" $x$ " in microns) upstream of the filter to the number of these particles downstream of the filter.

---

*Filtration, cleanliness level and  $\beta_x$ -ratio (recommended minimum)*

<b>Cleanliness per ISO 4406</b>	22/18/13
<b>Efficiency <math>\beta_x</math> (charge pressure filtration)</b>	$\beta_{15-20} = 75$ ( $\beta_{10} \geq 10$ )
<b>Efficiency <math>\beta_x</math> (suction and return line filtration)</b>	$\beta_{35-45} = 75$ ( $\beta_{10} \geq 2$ )
<b>Recommended inlet screen mesh size</b>	100 – 125 $\mu\text{m}$

## System design parameters

### Filtration

The suction filter is placed in the circuit between the reservoir and the inlet to the charge pump as shown in the accompanying illustration.

#### Suction filtration

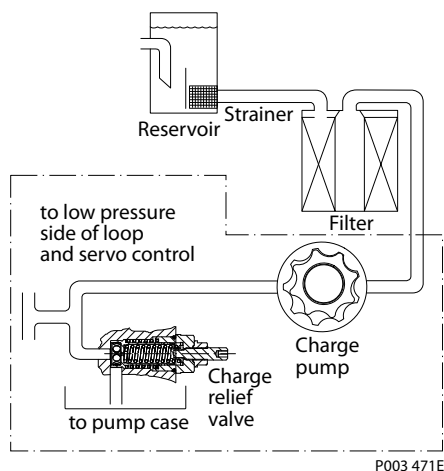

#### **Warning**

**Clogged filters can cause cavitation, which damages the charge pump.**

We recommend a filter bypass with a filter bypass sensor to prevent damage due to blocked suction filters.

### Charge pressure filtration (full charge pump flow)

For most H1 pumps exist two types of pressure filtration:

- remote pressure filtration (filter remotely mounted on vehicle)
- integral pressure filtration (filter mounted to the endcap)

Verify option availability in the size specific technical information. In either case the filtration circuit is the same with the filter element situated in the circuit downstream the charge pump and upstream of the charge relief valve such that full charge flow is continuously filtered, as shown in the accompanying illustrations.

Charge pressure filtration can mitigate high inlet vacuum in cold start-ups and provides fluid filtration immediately prior to entrance to the loop and the control system. Pressure filtration provides a higher level of filtering efficiency than suction filtration.

Filters used in charge pressure filtration circuits must be rated to at least 35 bar [508 psi] pressure.

A 100 – 125 µm screen located in the reservoir or in the charge inlet line is recommended when using charge pressure filtration.

A filter bypass valve is necessary to prevent filter damage and to avoid contaminants from being forced through the filter media by high pressure differentials across the filter.

In the event of high pressure drop associated with a blocked filter or cold start-up conditions, fluid will bypass the filter. Working with an open bypass should be avoided.

### Remote charge pressure filtration

Ports at the endcap are available to allow for the charge filter to be located conveniently for easy service and replacement. Care should be taken to minimize the hydraulic pressure drops associated with long connecting lines, small diameter hoses, or restrictive port adaptors at the filter head or endcap. Ensure the normal operating pressure drop across the remote filtration in and out ports is sufficiently below the crack pressure setting of the recommended filter bypass valve.

**System design parameters**

**⚠ Caution**

Remote filter heads without bypass and poor plumbing design can encounter excessive pressure drops that can lead to charge pump damage in addition to contaminants being forced through the filter media and into the transmission loop.

**Integral charge pressure filtration**

The H1 integral pressure filter head is designed with a filter bypass valve and noncontacting bypass sensor. The pressure differential acting on the filter element also acts on a spring biased bypass spool. This spool is designed with a magnetic area. When a certain spool position is reached, the magnet closes a switch in the bypass sensor which allows R2 to be in parallel with R1. This occurs without any mechanical contact between the spool and the bypass sensor.

The position of the bypass spool is indicated by the change in the measured sensor resistance. The change in resistance occurs when R2 is switched in and out of the circuit.

When the filter is not being bypassed, the nominal measured resistance is 510 Ω. When the switch is closed, the nominal measured resistance is 122 Ω.

The bypass spool is designed so the bypass sensor switch will be closed before oil bypasses the filter element. This gives the machine operator an indication that the filter is very close to bypassing and a filter replacement is required.

For cold start conditions, it is typical that the filter may bypass for a short amount of time while the oil is warming up. At normal operating oil temperatures, a system that does not yet need a filter replacement will operate in the non-bypass mode. The addition of an oil temperature sensor and additional control logic, is recommended to properly determine if a filter replacement is required.

*Integral filter head with filter bypass sensors*

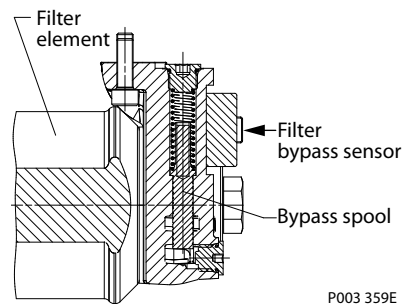

*Technical data, pressures*

<b>Filter bypass sensor switch closure Δp</b>	3.7 - 5.1 bar [54 - 74 psi]
<b>Bypass valve Δp</b>	5.6 ± 0.9 bar [80 ± 13 psi]

*Technical data, electric*

<b>Max. voltage</b>	48 V
<b>Max. power</b>	0.6 W
<b>Switch open</b>	510 Ω
<b>Switch closed</b>	122 Ω
<b>Resistor tolerance</b>	1 %
<b>Temperature range</b>	-20 ÷ +100 °C [-4 ÷ +212 °F]
<b>IP Rating (IEC 60 529) + DIN 40 050</b>	IP 69K part 9 with mating connector



**System design parameters**

*Min  $\beta_{7.5} (c)$  according to ISO 16889 (clean filter element only)*

Nominal flow at 30 mm <sup>2</sup> /s and $\Delta p$ 0.5 bar [7.3 psi]		
Short	60 l/min	Min $\beta_{7.5} (c) = 75$ ( $\beta_5 (c) \geq 10$ )
Medium	80 l/min	
Long	105 l/min	

*Schematic*

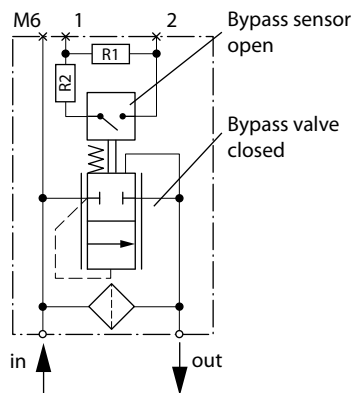

P003 195

*Connector*

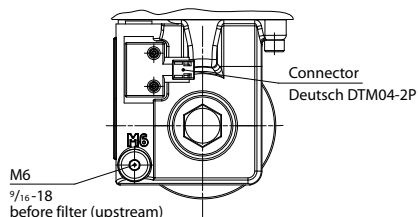

P003 198E

*Connector Pinout*

	Pin	Assignment	Or	Pin	Assignment
	1	Voltage	Alternative	1	Ground
	2	Ground		2	Voltage

P003 186

*H1 Filter bypass sensor mating connector parts list*

Description	Quantity	Order number
Mating connector	1	Deutsch DTM06-2S
Secondary wedge lock	1	Deutsch WM-2S
Socket terminal	2	Deutsch 0462-201-20141
Danfoss mating connector kit	1	11031205

**System design parameters**

The H1 pumps with an integrated filter option are shipped with a filter of length as indicated:

H1 pump size	Filter element length	Filter order number
H1P 069, 078, 089 and 100	Medium	11004918
H1P 115, 130, 147 and 165	Long	11004919

Below diagram shows the differential pressure between filter “in” and “out” with a filter element completely blocked, so that all flow runs across the filter bypass valve.

Filter bypass characteristic (completely blocked element)

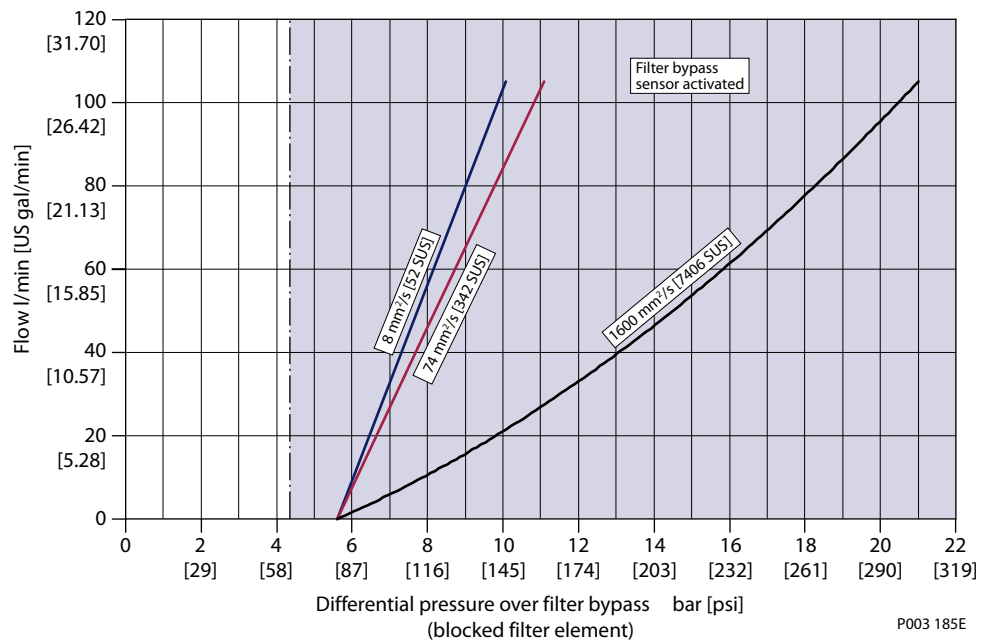

**Bypass sensor clearance**

The bypass sensor is activated by the magnetic bypass valve. No steel parts are allowed within a radius of 150 mm [5.91 in]. Moving steel devices or parts are not allowed within a radius of 250 mm [9.84 in].

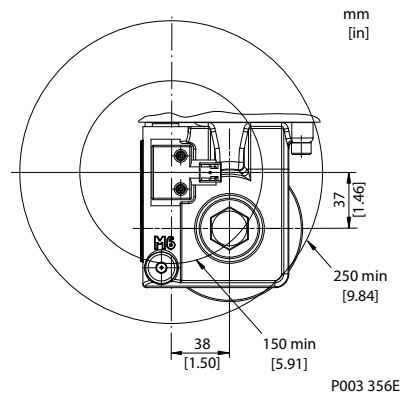

**System design parameters**

*Remote charge pressure filtration, full flow*

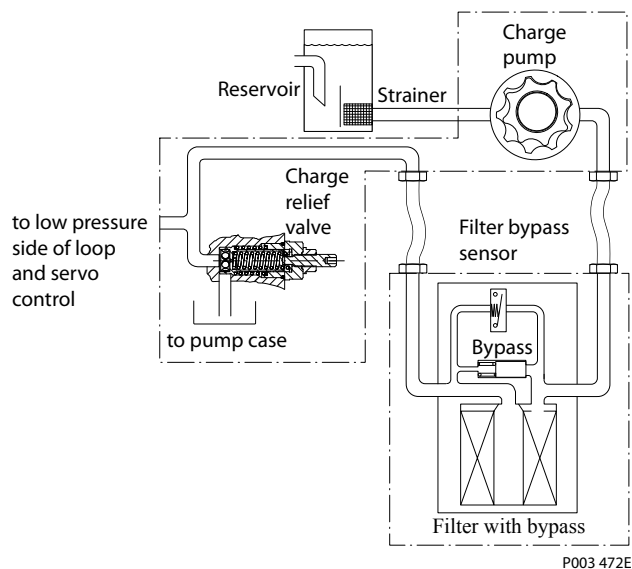

*Integral charge pressure filtration, full flow*

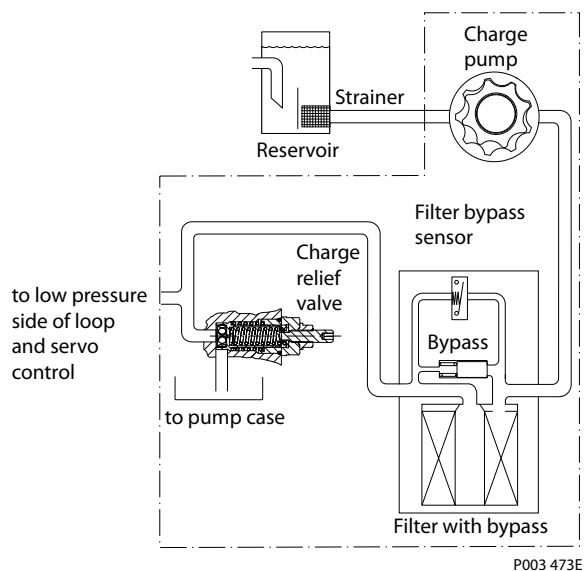

**Independent braking system**

**⚠ Warning**

**Unintended vehicle or machine movement hazard**

The loss of hydrostatic drive line power, in any mode of operation (forward, neutral, or reverse) may cause the system to lose hydrostatic braking capacity. You must provide a braking system, redundant to the hydrostatic transmission, sufficient to stop and hold the vehicle or machine in the event of hydrostatic drive power loss.

**System design parameters****Fluid selection**

Ratings and performance data are based on operating with hydraulic fluids containing oxidation, rust and foam inhibitors. These fluids must possess good thermal and hydrolytic stability to prevent wear, erosion, and corrosion of pump components.

**! Caution**

---

Never mix hydraulic fluids of different types.

---

**Reservoir**

The hydrostatic system reservoir should accommodate maximum volume changes during all system operating modes and promote de-aeration of the fluid as it passes through the tank. A suggested minimum total reservoir volume is  $\frac{5}{8}$  of the maximum charge pump flow per minute with a minimum fluid volume equal to  $\frac{1}{2}$  of the maximum charge pump flow per minute. This allows 30 seconds fluid dwell for removing entrained air at the maximum return flow. This is usually adequate to allow for a closed reservoir (no breather) in most applications.

Locate the reservoir outlet (charge pump inlet) above the bottom of the reservoir to take advantage of gravity separation and prevent large foreign particles from entering the charge inlet line. A 100-125  $\mu\text{m}$  screen over the outlet port is recommended. Position the reservoir inlet (fluid return) to discharge below the normal fluid level, toward the interior of the tank. A baffle (or baffles) will further promote de-aeration and reduce surging of the fluid.

**Case drain**

All single H1 pumps are equipped with multiple drain ports whereas some H1 pumps are equipped with two case drain port sizes. Port selection and case drain routing must enable the pump housing to maintain a volume of oil not less than half full and normal operating case pressure limits of the unit are maintained. Case drain routing and design must consider unit case pressure ratings.

A case drain line must be connected to one of the case outlets to return internal leakage to the system reservoir.

**System design parameters****Charge pump**

Charge flow is required on all H1 pumps applied in closed circuit installations. The charge pump provides flow to make up internal leakage, maintain a positive pressure in the main circuit, provide flow for cooling and filtration, replace any leakage losses from external valving or auxiliary systems, and to provide flow and pressure for the control system.

Many factors influence the charge flow requirements and the resulting charge pump size selection. These factors include system pressure, pump speed, pump swashplate angle, type of fluid, temperature, size of heat exchanger, length and size of hydraulic lines, control response characteristics, auxiliary flow requirements, hydrostatic motor type, etc. When initially sizing and selecting hydrostatic units for an application, it is frequently not possible to have all the information necessary to accurately evaluate all aspects of charge pump size selection.

Unusual application conditions may require a more detailed review of charge pump sizing. Charge pressure must be maintained at a specified level under all operating conditions to prevent damage to the transmission. Danfoss recommends testing under actual operating conditions to verify this.

**Charge pump sizing/selection**

In most applications a general guideline is that the charge pump displacement should be at least 10 % of the total displacement of all components in the system. Unusual application conditions may require a more detailed review of charge flow requirements. Please refer to *Selection of Drive Line Components*, **BLN-9885** for a detailed procedure.

System features and conditions which may invalidate the 10 % guideline include (but are not limited to):

- Continuous operation at low input speeds ( $< 1500 \text{ min}^{-1}$  (rpm))
- High shock loading and/or long loop lines
- High flushing flow requirements
- Multiple Low Speed High Torque motors
- High input shaft speeds

System design parameters

Bearing loads and life

Bearing life is a function of speed, system pressure, charge pressure, and swashplate angle, plus any external side or thrust loads. The influence of swashplate angle includes displacement as well as direction. External loads are found in applications where the pump is driven with a side/thrust load (belt or gear) as well as in installations with misalignment and improper concentricity between the pump and drive coupling. All external side loads will act to reduce the normal bearing life of a pump. Other life factors include oil type and viscosity.

In vehicle **propel drives** with no external shaft loads and where the system pressure and swashplate angle are changing direction and magnitude regularly, the normal  $L_{20}$  bearing life (80 % survival) will exceed the hydraulic load-life of the unit.

In **non propel drives** such as vibratory drives, conveyor drives or fan drives, the operating speed and pressure are often nearly constant and the swashplate angle is predominantly at maximum. These drives have a distinctive duty cycle compared to a propulsion drive. In these types of applications a bearing life review is recommended.

Applications with external shaft loads H1 pumps are designed with bearings that can accept some external radial and thrust loads. When external loads are present, the allowable radial shaft loads are a function of the load position relative to the mounting flange, the load orientation relative to the internal loads, and the operating pressures of the hydraulic unit. In applications where external shaft loads cannot be avoided, the impact on bearing life can be minimized by proper orientation of the load. Optimum pump orientation is a consideration of the net loading on the shaft from the external load, the pump rotating group and the charge pump load.

- In applications where the pump is operated such that nearly equal amounts of forward vs. reverse swashplate operation is experienced; bearing life can be optimized by orientating the external side load at  $0^\circ$  or  $180^\circ$  such that the external side load acts  $90^\circ$  to the rotating group load (for details see drawing below).
- In applications where the pump is operated such that the swashplate is predominantly ( $> 75\%$ ) on one side of neutral (e.g. vibratory, conveyor, typical propel); bearing life can be optimized by orientating the external side load generally opposite of the internal rotating group load. The direction of internal loading is a function of rotation and system port, which has flow out. Tables are available in the Controls section of each H1 size specific technical information that illustrates the flow out port as a function of pump rotation and energized EDC solenoid.
- H1 pumps are designed with bearings that can accept some thrust load such that incidental thrust loads are of no consequence. When thrust loads are anticipated the allowable load will depend on many factors and it is recommended that an application review be conducted.

Contact Danfoss for a bearing life review if external side loads are present.

Radial load position

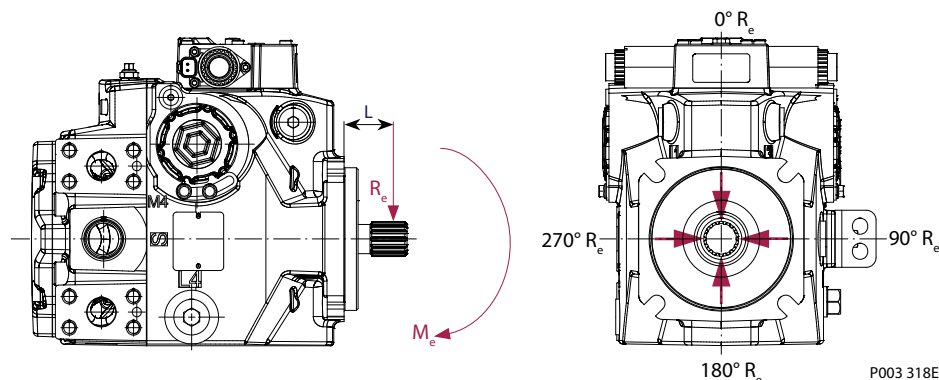

- $M_e$  = Shaft moment
- $L$  = Flange distance
- $R_e$  = External force to the shaft

Allowable shaft loads and moments are shown for each size specific technical information.

**System design parameters**

**Mounting flange loads**

Adding tandem mounted auxiliary pumps and/or subjecting pumps to high shock loads may result in excessive loading of the mounting flange. Applications which experience extreme resonant vibrations or shock may require additional pump support. The overhung load moment for multiple pump mounting may be estimated using the formula below:

*Overhung load example*

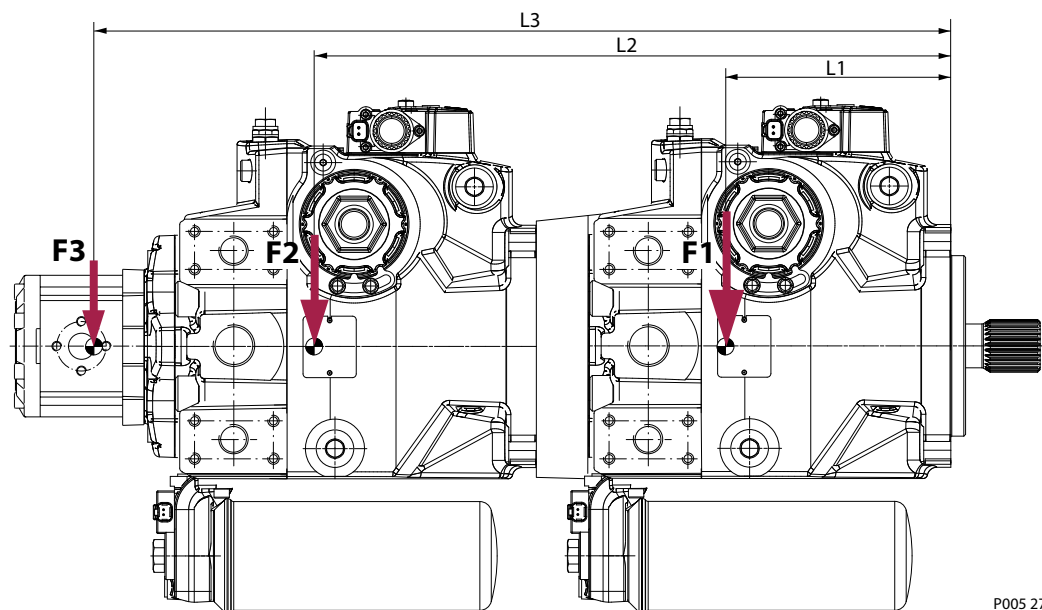

P005 275

Estimating overhung load moments, max. and rated acceleration factors for some typical applications:

**Rated load moment**

$$M_R = g \cdot G_R (W_1L_1 + W_2L_2 + \dots + W_nL_n) \text{ N}\cdot\text{m} \text{ [lb}\cdot\text{in]}$$

**Shock load moment**

$$M_S = g \cdot G_S (W_1L_1 + W_2L_2 + \dots + W_nL_n) \text{ N}\cdot\text{m} \text{ [lb}\cdot\text{in]}$$

*Variables:*

**g** = Gravity 9.81 m/s<sup>2</sup>

**G<sub>R</sub>** = Calculation factor for rated (vibratory) acceleration. This factor depends on the application.

**G<sub>S</sub>** = Calculation factor for max. shock acceleration. This factor depends on the application.

**W** = Mass/Weight of pump, kg [lb]

**L** = Distance from mounting flange to pump center of gravity, m [in] (refer to Installation drawings.)

Allowable overhung load moment values are given for each size specific technical information. Exceeding these values requires additional pump support.

*Typical G loads for various applications*

Application	Calculation factor	
	Rated (vibratory) acceleration G <sub>R</sub>	Maximum (shock) acceleration G <sub>S</sub>
Skid Steer Loader	8	15-20
Trencher (rubber tires)	3	8
Asphalt Paver	2	6
Windrower	2	5
Aerial Lift, Turf Care	1.5	4
Vibratory Roller	6	10

Use these in the absence of specific data for a rough estimation.

**System design parameters**



**System design parameters****Shaft torque**

The **rated torque** is a measure of tooth wear and is the torque level at which a normal spline life of 2 x 10<sup>9</sup> shaft revolutions can be expected. The rated torque presumes a regularly maintained minimum level of lubrication via a moly-disulfide grease in order to reduce the coefficient of friction and to restrict the presence of oxygen at the spline interface. It is also assumed that the mating spline has a minimum hardness of Rc 55 and full spline depth. The rated torque is proportional to the minimum active spline length.

**Maximum torque** ratings are based on torsional fatigue strength considering 100.000 full load reversing cycles. However, a spline running in oil-flooded environment provides superior oxygen restriction in addition to contaminant flushing. The rated torque of a flooded spline can increase to that of the maximum published rating. A flooded spline would be indicative of a pump driven by a pump drive or plugged into an auxiliary pad of a pump.

Maintaining a spline engagement at least equal to the Pitch Diameter will also maximize spline life. Spline engagements of less than  $\frac{3}{4}$  Pitch Diameter are subject to high contact stress and spline fretting.

**Shaft torque for tapered shafts**

The **rated torque** is based on the contact pressure between the shaft and hub surfaces with poor surface contact areas. With an increased quality of the contact areas, the contact pressure between the shaft and hub is increased and allows higher torque to be transmitted.

When a key is used for orientation of the hub on the shaft in conjunction with poor quality contact surfaces, the transmitted torque will drop significantly. This is due to the key carrying the torque, which limits the shaft torque carrying capability.

**Maximum torque** rating is based on an ideal contact area of 100 % and the retaining nut properly torqued. This allows for the highest contact pressure between the shaft and the hub.

**System design parameters**

**Shaft availability and torque ratings**

Alignment between the mating spline's Pitch Diameters is another critical feature in determining the operating life of a splined drive connection. Plug-in, or rigid spline drive installations can impose severe radial loads on the shafts.

The radial load is a function of the transmitted torque and shaft eccentricity. Increased spline clearance will not totally alleviate this condition; BUT, increased spline clearance will prevent mechanical interference due to misalignment or radial eccentricity between the pitch diameters of the mating splines. Spline life can be maximized if an intermediate coupling is introduced between the bearing supported splined shafts.

Multiple pump installations must consider the loads from the entire pump stack and all torques are additive. Charge pumps loads must also be included.

*Through torque diagram*

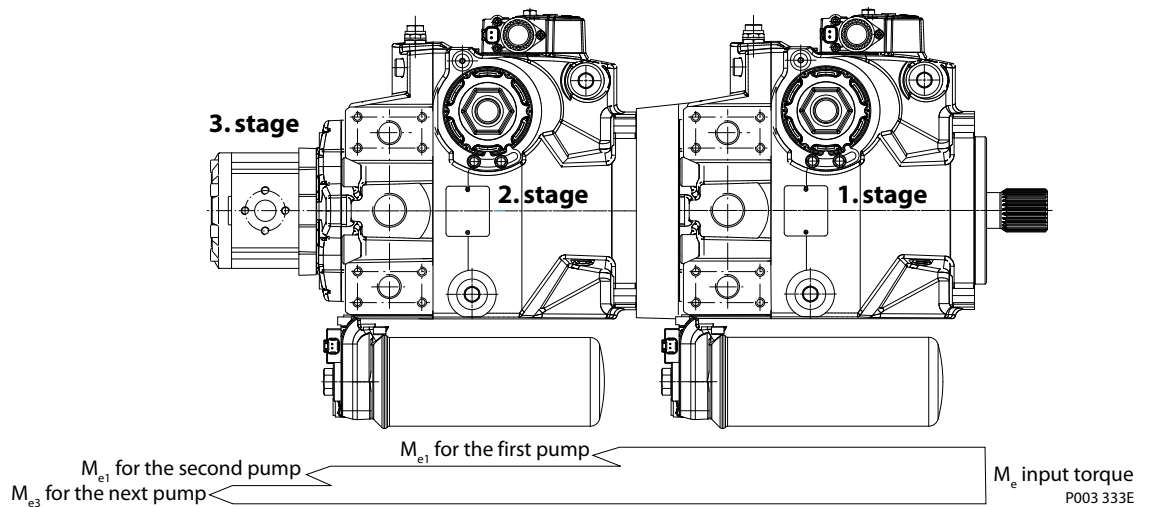

**! Caution**

**Ensure requirements do not exceed shaft torque ratings. Torque required by auxiliary pumps is additive.**

Rated and maximum torque ratings for each available shaft is shown in the H1 size specific technical information.

**System design parameters****Understanding and minimizing system noise**

Noise is transmitted in fluid power systems in two ways: as fluid borne noise, and structure borne noise.

**Fluid-borne noise** (pressure ripple or pulsation) is created as pumping elements discharge oil into the pump outlet. It is affected by the compressibility of the oil, and the pump's ability to transition pumping elements from high to low pressure. Pulsations travel through the hydraulic lines at the speed of sound (about 1400 m/s [4600 ft/sec] in oil) until there is a change (such as an elbow) in the line. Thus, amplitude varies with overall line length and position.

**Structure born noise** is transmitted wherever the pump casing connects to the rest of the system. The way system components respond to excitation depends on their size, form, material, and mounting.

---

[System lines and pump mounting can amplify pump noise.](#)

---

**Follow these suggestions to help minimize noise in your application:**

- Use flexible hoses.
- Limit system line length.
- If possible, optimize system line position to minimize noise.
- If you must use steel plumbing, clamp the lines.
- If you add additional support, use rubber mounts.
- Test for resonants in the operating range; if possible avoid them.

**System design parameters**

**Determination of nominal pump sizes**

Generally, the sizing process is initiated by an evaluation of the machine system to determine the required motor speed and torque to perform the necessary work function.

Use the following formulae to determine the nominal pump size for a specific application:

	<b>Metric System</b>	<b>Inch System</b>
<b>Output flow</b>	$Q_e = \frac{V_g \cdot n \cdot \eta_v}{1000}$ (l/min)	$Q_e = \frac{V_g \cdot n \cdot \eta_v}{231}$ (US gal/min)
<b>Input torque</b>	$M_e = \frac{V_g \cdot \Delta p}{20 \cdot \pi \cdot \eta_m}$ (N·m)	$M_e = \frac{V_g \cdot \Delta p}{2 \cdot \pi \cdot \eta_m}$ (lbf·in)
<b>Input power</b>	$P_e = \frac{M_e \cdot n \cdot \pi}{30\,000} = \frac{Q_e \cdot \Delta p}{600 \cdot \eta_t}$ (kW)	$P_e = \frac{M_e \cdot n \cdot \pi}{198\,000} = \frac{Q_e \cdot \Delta p}{1714 \cdot \eta_t}$ (hp)

Variables:

- V<sub>g</sub>** = Displacement per rev.
- p<sub>HP</sub>** = High pressure
- p<sub>NP</sub>** = Low pressure
- Δp** = p<sub>HP</sub> - p<sub>NP</sub>
- n** = Input speed
- η<sub>v</sub>** = Volumetric efficiency
- η<sub>m</sub>** = Mechanical (torque) efficiency
- η<sub>t</sub>** = Overall efficiency (η<sub>v</sub> · η<sub>m</sub>)

SI units [US units]:

- cm<sup>3</sup>/rev [in<sup>3</sup>/rev]
- bar [psi]
- bar [psi]
- bar [psi]
- min<sup>-1</sup> (rpm)

First, the motor is sized to transmit the maximum required torque. The pump is then selected as a flow source to achieve the maximum motor speed. For more details see *Selection of Drive Line Components*, **BLN-9885**.







**Products we offer:**

- Bent Axis Motors
- Closed Circuit Axial Piston Pumps and Motors
- Displays
- Electrohydraulic Power Steering
- Electrohydraulics
- Hydraulic Power Steering
- Integrated Systems
- Joysticks and Control Handles
- Microcontrollers and Software
- Open Circuit Axial Piston Pumps
- Orbital Motors
- PLUS+1® GUIDE
- Proportional Valves
- Sensors
- Steering
- Transit Mixer Drives

**Danfoss Power Solutions** is a global manufacturer and supplier of high-quality hydraulic and electronic components. We specialize in providing state-of-the-art technology and solutions that excel in the harsh operating conditions of the mobile off-highway market. Building on our extensive applications expertise, we work closely with our customers to ensure exceptional performance for a broad range of off-highway vehicles.

We help OEMs around the world speed up system development, reduce costs and bring vehicles to market faster.

Danfoss – Your Strongest Partner in Mobile Hydraulics.

**Go to [www.powersolutions.danfoss.com](http://www.powersolutions.danfoss.com) for further product information.**

Wherever off-highway vehicles are at work, so is Danfoss. We offer expert worldwide support for our customers, ensuring the best possible solutions for outstanding performance. And with an extensive network of Global Service Partners, we also provide comprehensive global service for all of our components.

Please contact the Danfoss Power Solution representative nearest you.

**Comatrol**

[www.comatrol.com](http://www.comatrol.com)

**Turolla**

[www.turollaocg.com](http://www.turollaocg.com)

**Hydro-Gear**

[www.hydro-gear.com](http://www.hydro-gear.com)

**Daikin-Sauer-Danfoss**

[www.daikin-sauer-danfoss.com](http://www.daikin-sauer-danfoss.com)

Local address:

**Danfoss Power Solutions (US) Company**  
2800 East 13th Street  
Ames, IA 50010, USA  
Phone: +1 515 239 6000

**Danfoss Power Solutions GmbH & Co. OHG**  
Krokamp 35  
D-24539 Neumünster, Germany  
Phone: +49 4321 871 0

**Danfoss Power Solutions ApS**  
Nordborgvej 81  
DK-6430 Nordborg, Denmark  
Phone: +45 7488 2222

**Danfoss Power Solutions Trading (Shanghai) Co., Ltd.**  
Building #22, No. 1000 Jin Hai Rd  
Jin Qiao, Pudong New District  
Shanghai, China 201206  
Phone: +86 21 3418 5200

Danfoss can accept no responsibility for possible errors in catalogues, brochures and other printed material. Danfoss reserves the right to alter its products without notice. This also applies to products already on order provided that such alterations can be made without changes being necessary in specifications already agreed. All trademarks in this material are property of the respective companies. Danfoss and the Danfoss logotype are trademarks of Danfoss A/S. All rights reserved.