

# MZ02 - MZE02

## HYDRAULIC MOTORS



T E C H N I C A L   C A T A L O G



# OVERVIEW

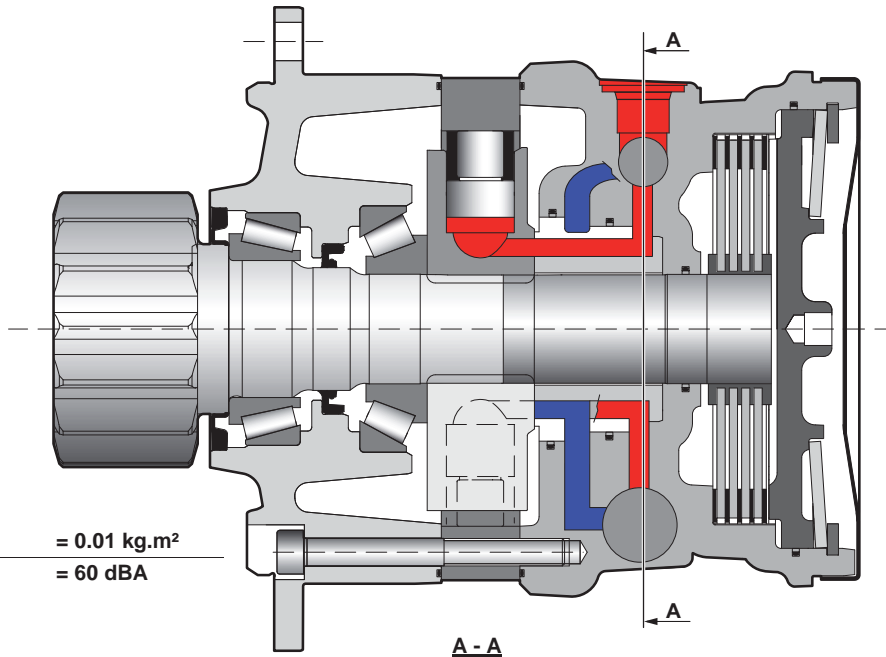

Motor inertia = 0.01 kg.m<sup>2</sup>  
 Noise emissions = 60 dBA

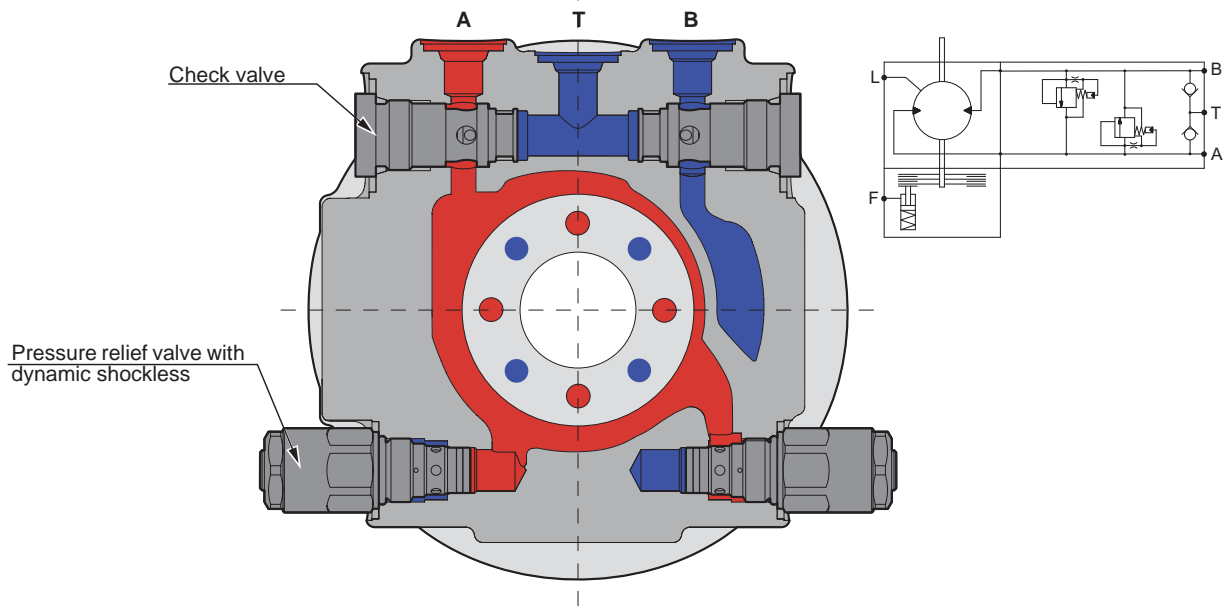

	C	① cm <sup>3</sup> /rev [cu.in/rev.]	Theoretical torque		Max.power ① kW [HP]	Max. speed ① rev/min[RPM]	Max. pressure bar [PSI]
			at 100 bar Nm	at 1000 PSI [lb.ft]			
Cams with equal lobes MZ02	0	213 [13.0]	339	[172]	18 [24]	470*	260 [3 771]
	1	235 [14.3]	374	[190]		430*	
	2	255 [15.6]	405	[206]		395*	
MZE02	0	332 [20.2]	528	[268]	22 [30]	265*	260 [3 771]
	1	364 [22.2]	579	[294]		245*	
	2	398 [24.3]	633	[322]		225*	

\* See option "M" for higher speed or lower charge pressure.

① First displacement



# CONTENT

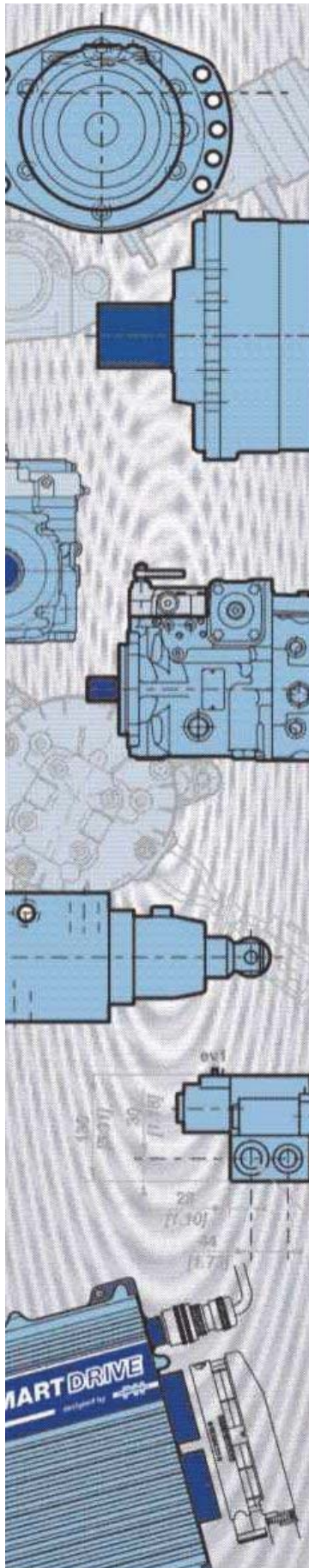

**MODEL CODE** 4 →

Model code

**CHARACTERISTICS** 7 →

Dimensions for standard 1-displacement motor	7
Pinion characteristics	8
	8

Characteristics

**VALVING SYSTEMS** 11 →

Hydraulic connections	11
Valves description	12

Valving systems

**BRAKES** 13 →

Rear brake	13
Automatic electrical de-braking valve	14

Brakes

**INSTALLATION** 15 →

Hydraulic motor setting	15
Customer's chassis recommendations	15

Installation

**OPTIONS** 17 →

Options



# MODEL

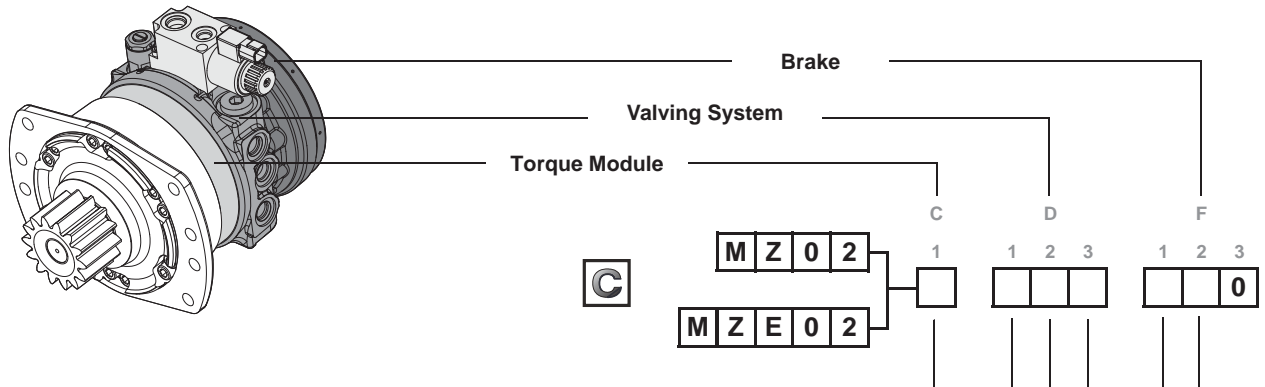

**C1**  
**Cam ring type**

		1 displacement	
		cm <sup>3</sup> /rev. [cu.in/rev.]	
Cams with equal lobes	MZ02	213 [13.0]	0
		235 [14.3]	1
		255 [15.6]	2
Cams with equal lobes	MZE02	332 [20.2]	0
		364 [22.2]	1
		398 [24.3]	2

**D1**  
**Valves**

Check valve	Pressure relief valve	Pressure relief valve with dynamic shockless	
Yes	Yes	No	A
Yes	No	Yes	B

**D2**  
**Pressure relief valve setting**  
Pressure settings and Dynamic shockless timing will be precisely determined based on machine design. (see possible settings on page 12)

**D3**  
**Connection type**

UNF (SAE) ISO 11926-1	A
GAZ (BSPP) JIS B2351	F

**F1**  
**Rear brake**  
mini./max. torque (N.m [lb.ft])

1 480 [1 092] / 1 830 [1 350]	F
890 [656] / 1100 [811]	J

**F2**  
**Debraking valve**

Without debraking valve	1
Automatic electrical debraking valve	3



# CODE

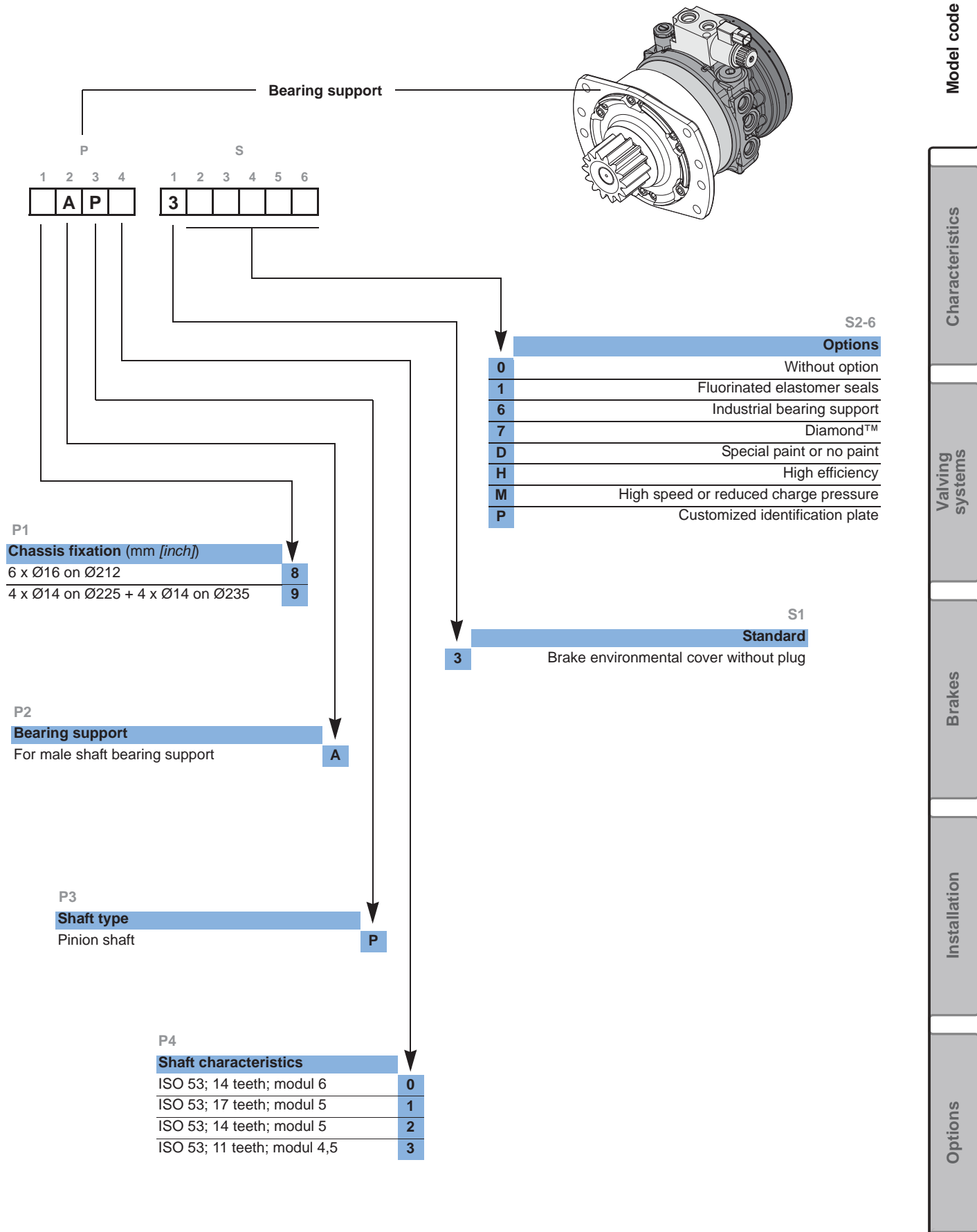



**Methodology :**

This document is intended for manufacturers of machines that incorporate Poclain Hydraulics products. It describes the technical characteristics of Poclain Hydraulics products and specifies installation conditions that will ensure optimum operation. This document includes important comments concerning safety. They are indicated in the following way:



**Safety comment.**

This document also includes essential operating instructions for the product and general information. These are indicated in the following way:



**Essential instructions.**



**General information .**



**Information on the model number.Information on the model code.**



**Weight of component without oil.**



**Volume of oil.**



**Units.**



**Tightening torque.**



**Screws.**



**Information intended for Poclain-Hydraulics personnel.**

The views in this document are created using metric standards.

The dimensional data is given in mm and in inches (inches are between brackets and italic)



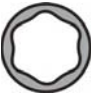

# CHARACTERISTICS

## Dimensions for standard 1-displacement motor

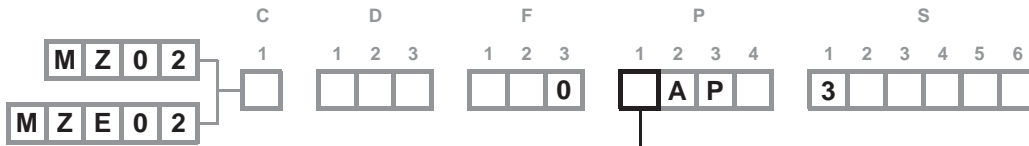

### 8 Ear fixation 6 x Ø 16

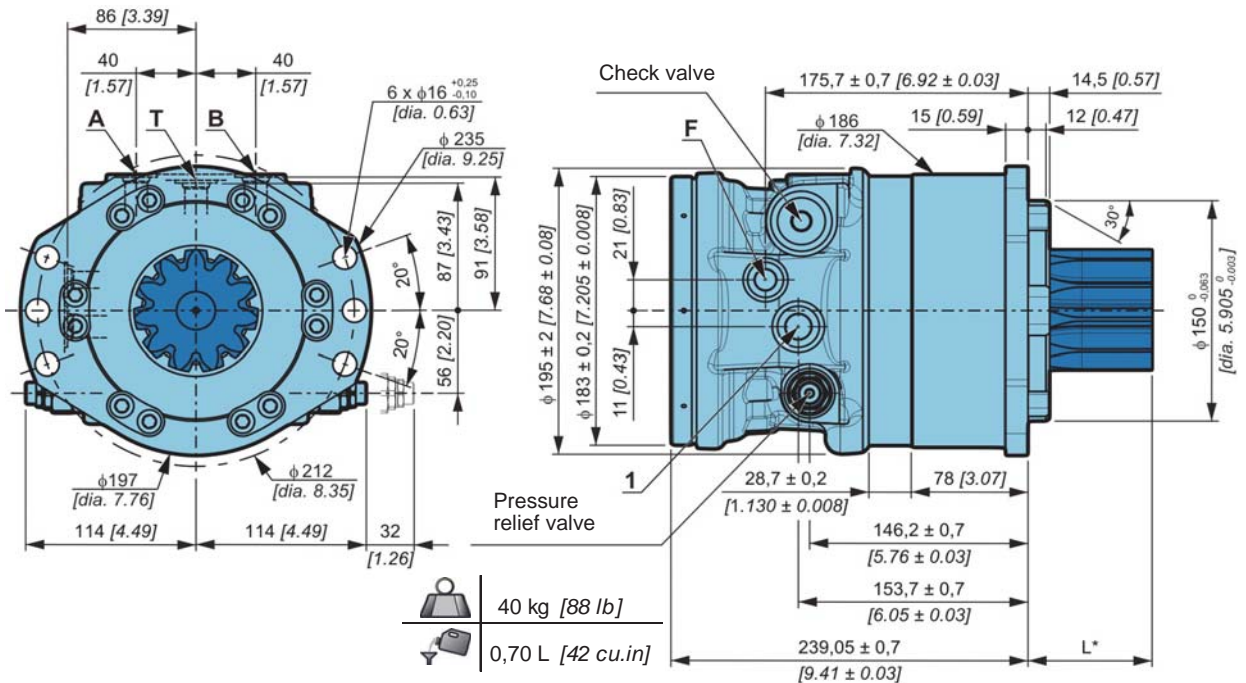

### 9 Ear fixation 8 x Ø 14

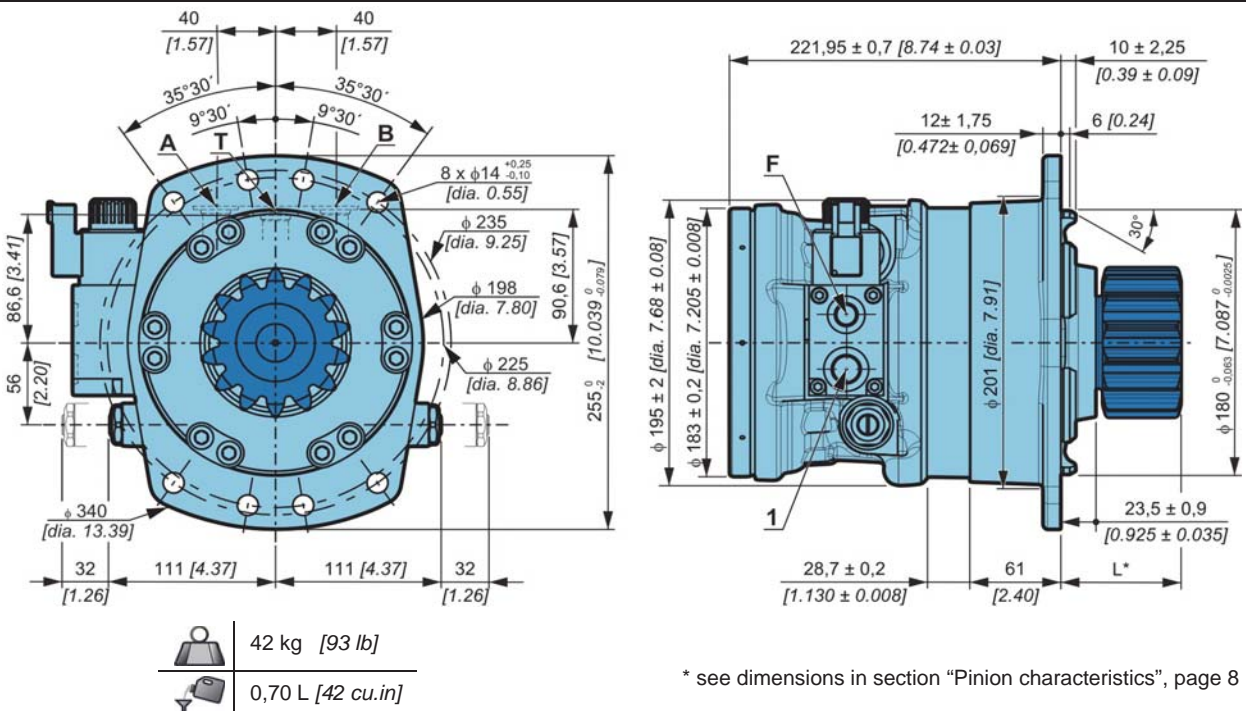

\* see dimensions in section "Pinion characteristics", page 8



**Pinion characteristics**

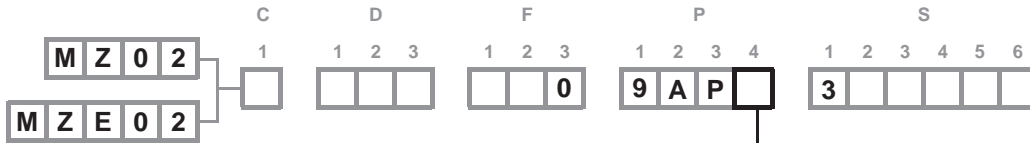

0

1

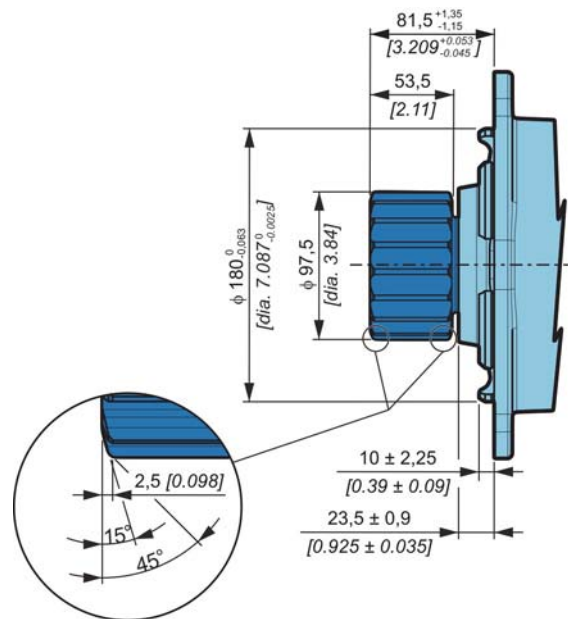
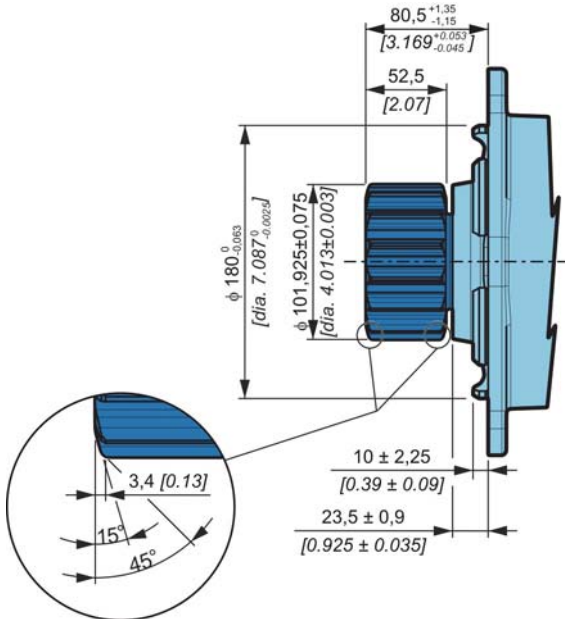

Norm	NF ISO 53
Module	6
Number of teeth	14
Pitch diameter	84 mm [3.31 inch]
Pressure angle	20°

Norm	NF ISO 53
Module	5
Number of teeth	17
Pitch diameter	85 mm [3.35 inch]
Pressure angle	20°

2

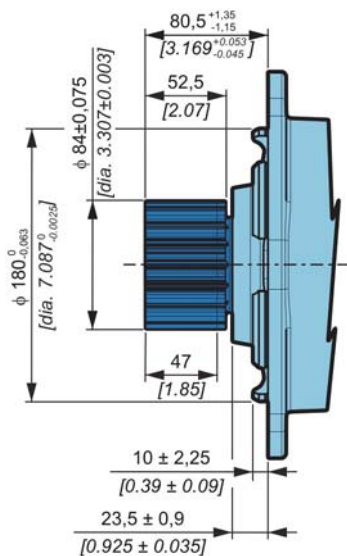

Norm	NF ISO 53
Module	5
Number of teeth	14
Pitch diameter	70 mm [2.76 inch]
Pressure angle	20°



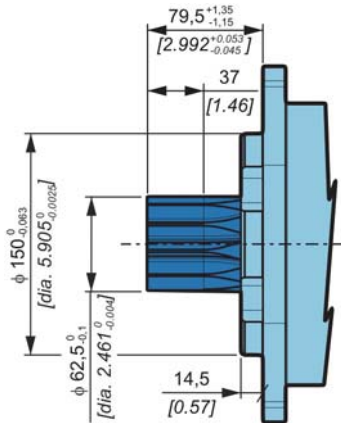
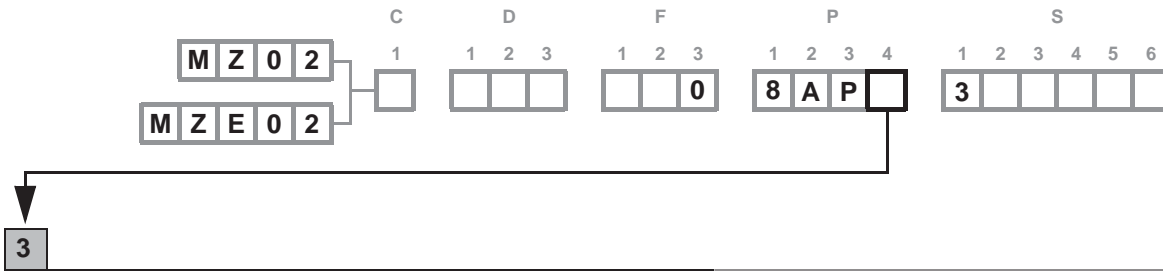
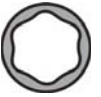

Norm	NF ISO 53
Module	4,5
Number of teeth	11
Pitch diameter	49,5 mm [1.95 inch]
Pressure angle	20°

### Treated shafts

Heat treatment is applied on the whole surface of all shafts.

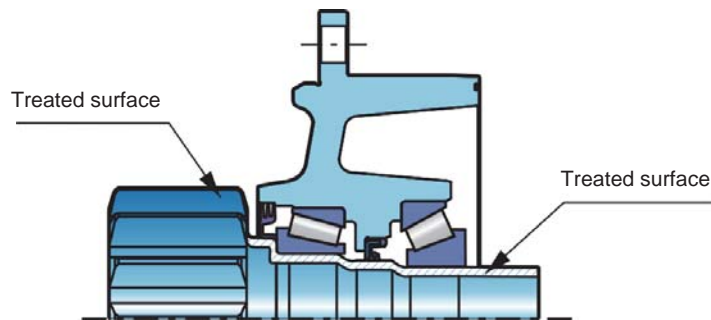

Model code

Characteristics

Valving systems

Brakes

Installation

Options





# VALVING SYSTEMS

## Hydraulic connections

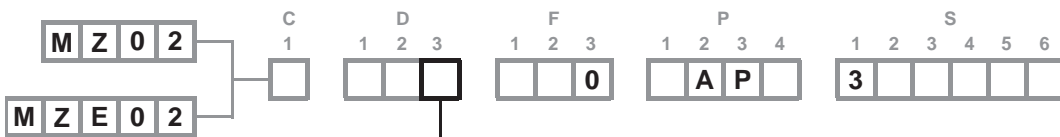
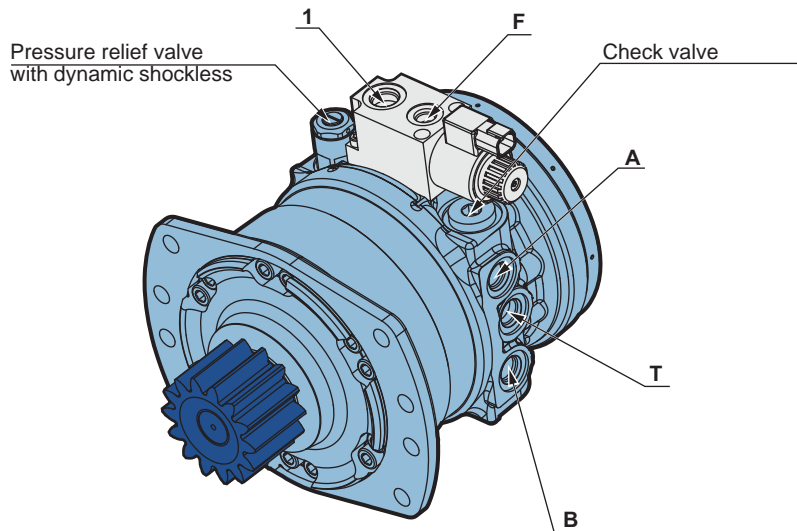

	Standards	Power supply	Case drain	Control of parking brake	Charge pressure	
		A-B	1	F	T	
A	UNF (SAE)	ISO 11 926-1	3/4"-16 UNF	3/4"-16 UNF	9/16"-18 UNF	3/4"-16 UNF
F	GAZ (BSPP)	JIS B2351	3/8"	3/8"	1/4"	3/8"

Max. pressures	MZ MZE bar [PSI]	260 [3 771] 260 [3 771]	2.5 [36]	35 [508]	260 [3 771]
Instantaneous pressure peaks resistance			15 [218]		



You are strongly advised to use the fluids specified in brochure "Installation guide" N° 801478197L.



To find the connections' tightening torques, see the brochure "Installation guide" N° 801478197L.



### Valves description

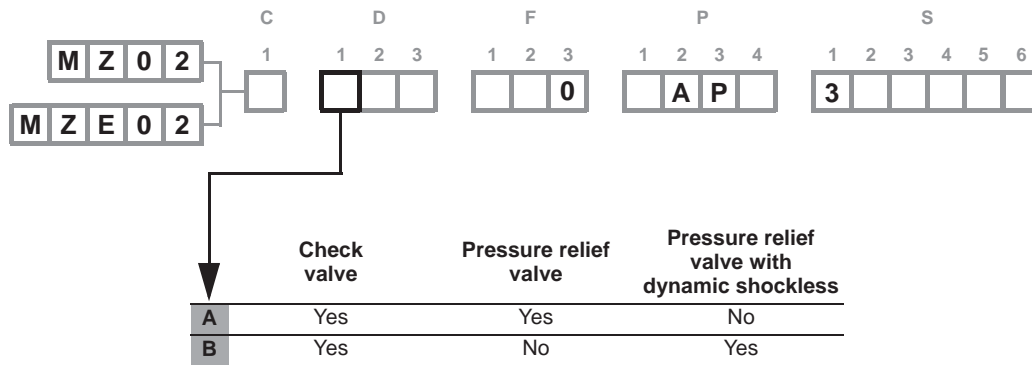

### Check valve

The check valve allows to compensate for leakages to prevent cavitation.



Flow rate l/min [GPM]	Operating pressure bar [PSI]	Cracking pressure bar [PSI]	Temperature range °C [°F]	Viscosity range mm <sup>2</sup> /s	Filtration NAS 1638
100 [26.4]	350 [5 076]	0,5 [7.2]	-20 to +70 [-4 to 158]	15 to 380	8

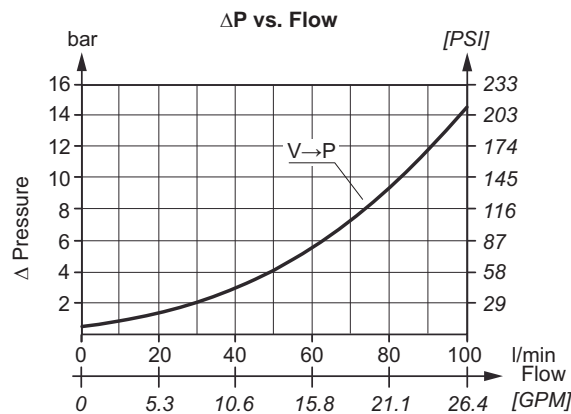

### Pressure relief valve

The pressure relief valve limits the pressure in the high pressure lines of the hydraulic motor.

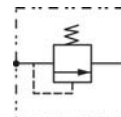

### Pressure relief valve with dynamic shockless

The pressure relief valve with dynamic shockless:

- limits the pressure in the high pressure lines of the hydraulic motor.
- allows the absorption of the pressure peacks.

Valve characteristics:

- Max. flow: 60l/min [15.85 gal/min]
- Shockless time: from 0,05 to 0,3 s
- Max. pressure setting: 260 bar [3771 PSI]

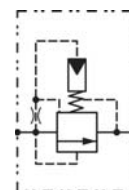

Other valve sizes are available. Consult your Poclain Hydraulics application engineer for further information.



# BRAKES

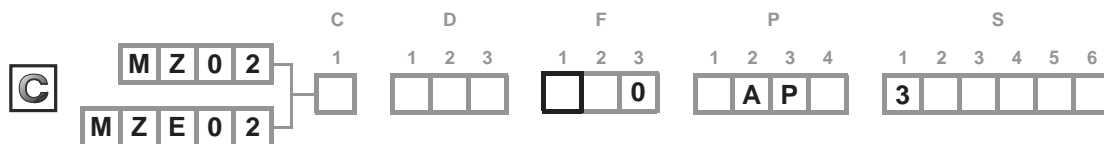

## Rear brake

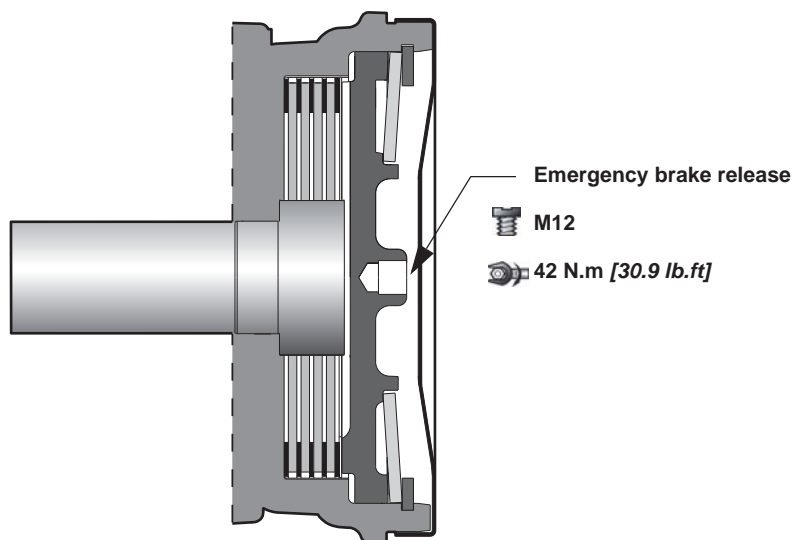

### Brake principle

This is a multidisc brake which functions through the absence of pressure. The spring exerts a force on the piston, which acts on the fixed and mobile discs, and thus immobilizes the shaft. The braking torque decreases in linear proportion to the brake release pressure.

	F 1 2 3		F 1 2 3	
	F	0	J	0
Parking brake torque at 0 bars on housing	Max.	1 830 Nm [1 350 lb.ft]	1 100 Nm [810 lb.ft]	
	Mini.	1 480 Nm [1 090 lb.ft]	890 Nm [660 lb.ft]	
Min. brake release pressure		12 bar [174 PSI]	12 bar [174 PSI]	
Max. brake release pressure		35 bar [508 PSI]	35 bar [508 PSI]	
Volume for brake release		19 cm <sup>3</sup> [1,2 cu.in]	19 cm <sup>3</sup> [1,2 cu.in]	



Do not run-in the multidisc brakes.



Your duty cycles and especially brake cycles must be validated by your Poclain Hydraulics application engineer.



**Automatic electrical de-braking valve**

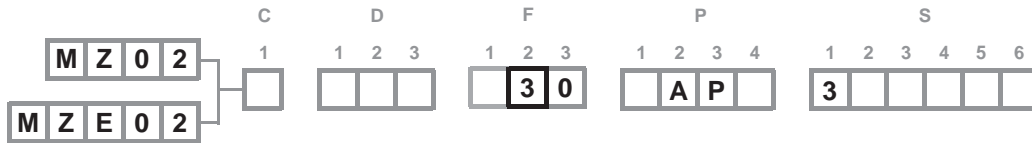

Electrical de-braking valve controls braking / brake release of the hydraulic motor's static brake after "left rotation" and "right rotation" information issued from hydraulic joystick.

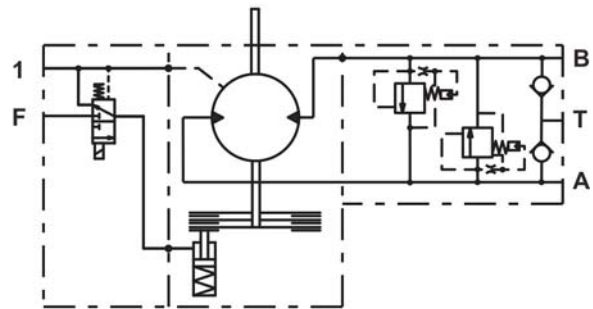
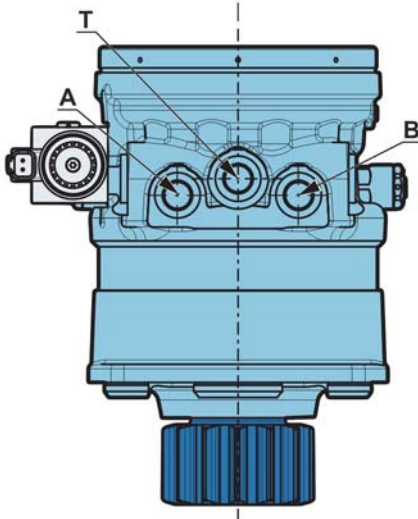
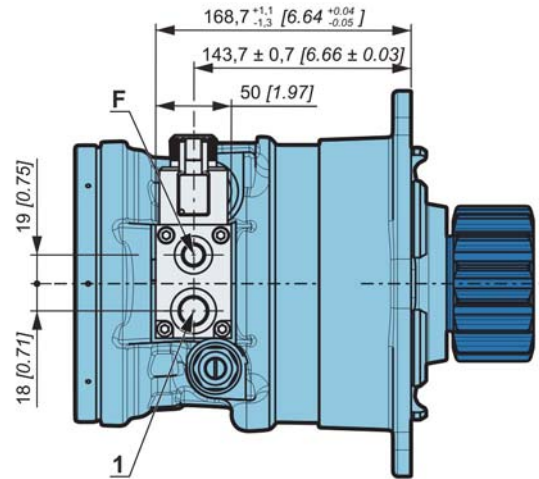
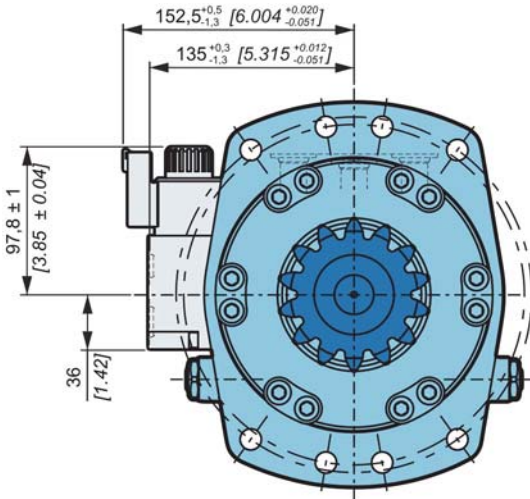

**Electrical de-braking ports characteristics**

Port	Function	ISO 1179-1 (GAZ)	ISO 11926-1 (UNF)
F	Brake pressure	G 1/4"	9/16-18 UNF-2B
1	Drain	G 3/8"	3/4-16 UNF-2B

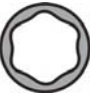

# INSTALLATION

## Hydraulic motor setting

Set the pinion shaft of hydraulic motor depending on the minimum radius of the ring gear (distance A), usually indicated with a point on the ring gear by the manufacturer.

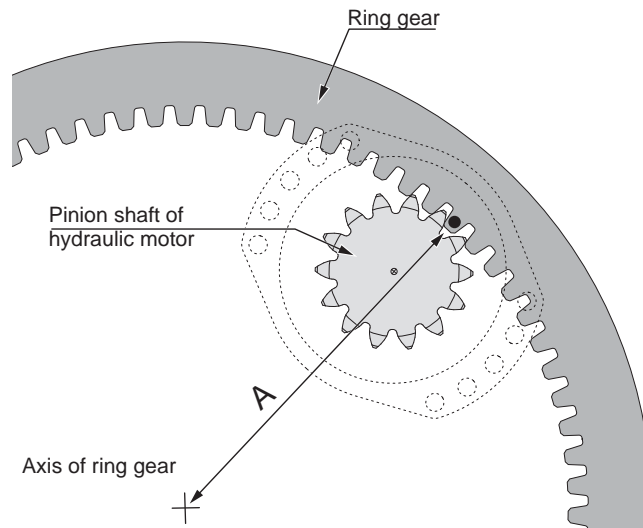

## Customer's chassis recommendations

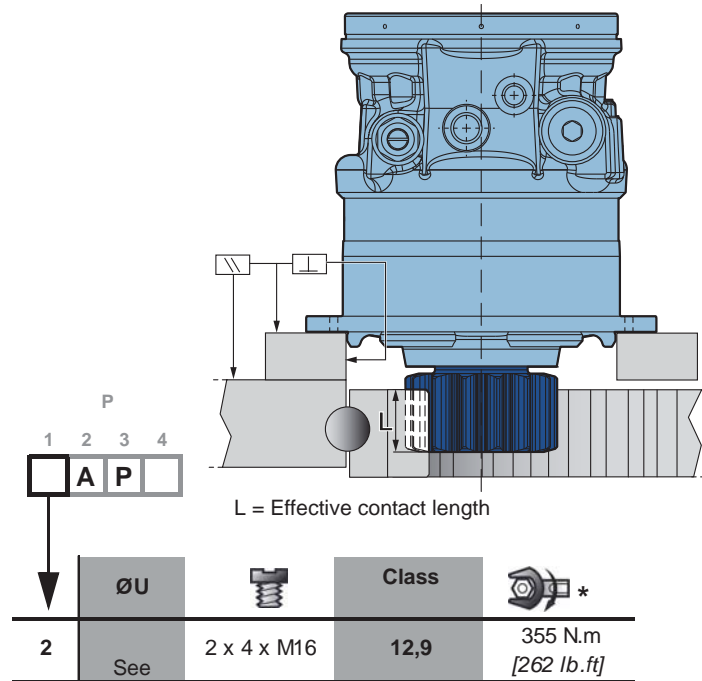
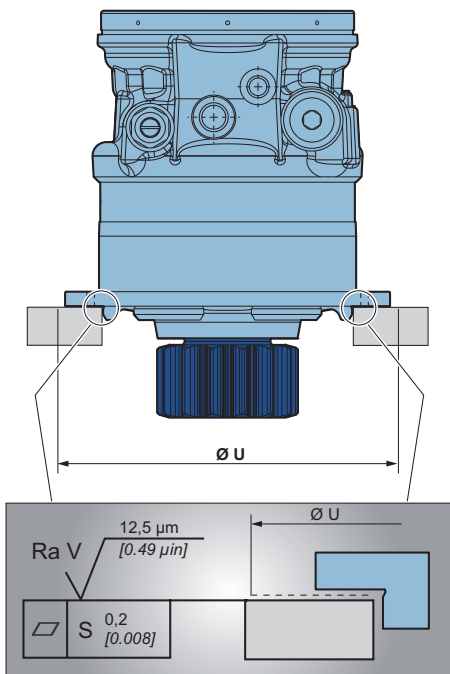

page 7

CHC type only

\* : Min. values for torque and load to be transmitted



Take care over the immediate environment of the connections.







# OPTIONS

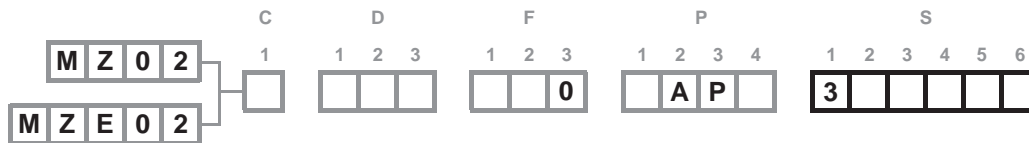

You can accumulate more than one optional part. Consult your Poclain Hydraulics sales engineer.

## 3 Brake environmental cover without plug

No plug or hole in the cover.

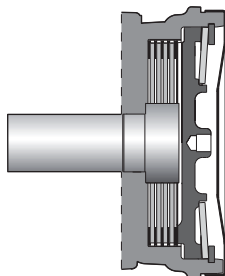

## 1 Fluorinated elastomer seals

Nitrile seals marked in the figure below replaced by fluorinated elastomer seals.

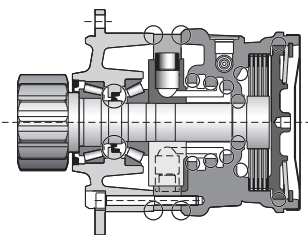

Consult your Poclain Hydraulics sales engineer.

## 6 Industrial support

Reduction of around 50% from the rated value in the bearings' preload value. Without external loads, increases the lifetime of the bearing support.



For a precise calculation, consult your Poclain Hydraulics application engineer.

## 7 Diamond™

Special treatment of the motor core which considerably increases its strength, making the motor much more tolerant to temporary instances of the operating conditions being exceeded.

Model code

Characteristics

Valving systems

Brakes

Installation

Options



## **D** Special paint or no paint

The motors are delivered with Poclain Hydraulics yellow ochre primer as standard.



Consult your Poclain Hydraulics application engineer for other colors of primer or topcoat.

## **H** High efficiency

Reinforced piston sealing to improve volumetric efficiency.



For a precise calculation, consult your Poclain Hydraulics application engineer.

## **M** High speed or reduced charge pressure

Option M leads to:

- In the case of MZ02: Reduction in charge pressure.
- In the case of MZE02: An increase in speed limit and a reduction in charge pressure.



For a precise calculation, consult your Poclain Hydraulics application engineer.

## **P** Customized identification plate

Your part number can be engraved on the plate.



Consult your Poclain Hydraulics application engineer for other possibilities.



Model code

Characteristics

Valving systems

Brakes

Installation

Options



*Poclain Hydraulics reserves the right to make any modifications it deems necessary to the products described in this document without prior notification. The information contained in this document must be confirmed by Poclain Hydraulics before any order is submitted.*

*Illustrations are not binding.*

*The Poclain Hydraulics brand is the property of Poclain Hydraulics S.A.*

 15/03/2017



 A40708X

